

DRIVE SHAFT AND AXLE**4110-01/4110-03/4115-01/4220-01/4220-03/4221-01****INDEX****DRIVE SHAFT AND AXLE****GENERAL INFORMATION**

- | | |
|---|---|
| 1. SPECIFICATION..... | 3 |
| 2. MAJOR CHANGES (as of Feb. 2014)..... | 4 |

OVERVIEW AND OPERATING PROCESS

- | | |
|----------------------|---|
| 1. COMPONENT..... | 4 |
| 2. TORQUE STEER..... | 5 |
| 3. REAR AXLE..... | 6 |

REMOVAL AND INSTALLATION

- | | |
|---|----|
| 4220-00 TROUBLESHOOTING..... | 7 |
| 4115-01 FRONT HUB AND KNUCKLE | 8 |
| 4221-01 REAR HUB AND KNUCKLE
(FOR 4WD) | 14 |
| 4221-01 REAR HUB AND KNUCKLE
(FOR 2WD)..... | 21 |
| 4110-01 FRONT DRIVE SHAFT
(FOR 4WD)..... | 29 |
| 4220-03 REAR DRIVE SHAFT
(FOR 4WD) | 36 |
| 4110-03 DRIVE SHAFT BOOT..... | 41 |
| 4220-01 REAR AXLE (FOR 4WD)..... | 47 |
| 4220-01 DISASSEMBLY AND
REASSEMBLY OF REAR AXLE
ASSEMBLY..... | 52 |

دیجیتال خودرو

شرکت دیجیتال خودرو سامانه (مسئولیت محدود)

اولین سامانه دیجیتال تعمیرکاران خودرو در ایران



DRIVE SHAFT AND AXLE**4110-01****GENERAL INFORMATION****1. SPECIFICATION**

Component		Item	Specifications
2WD, 4WD	Front drive shaft	Joint type	Inside: Tripod joint Outside: Ball joint
		Max. allowed angle	Inside: 23° Outside: 46°
		To compensate the bending angle	Installation of equivalent length shaft
4WD only	Rear drive shaft	Joint type	Inside: Cross groove joint Outside: Ball joint
		Max. allowed angle	Inside: 23° Outside: 23°
	Rear differential carrier	Type	Independent Rear Drive Axle (IRDA)
		Reduction gear type	Hypoid gear
		Gear reduction ratio	2.93
		Diameter of gear	Ø152 mm
		Oil type	Hypoid gear oil (SAE 75W/90)
		Final drive gear backlash	0.10 to 0.15 mm
	Propeller shaft	Differential gear backlash	0 to 0.076 mm
		Joint type	PTU side: CV joint Rear axle side: Rubber coupling
Sliding distance		±25 mm or more	
Unbalance		80 g.mm or less at 3,500 rpm	
	Total runout	0.3 mm or less	

Modification basis	
Application basis	
Affected VIN	

DRIVE SHAFT AND AXLE

KORANDO 2015.01

2. MAJOR CHANGES (as of Feb. 2014)

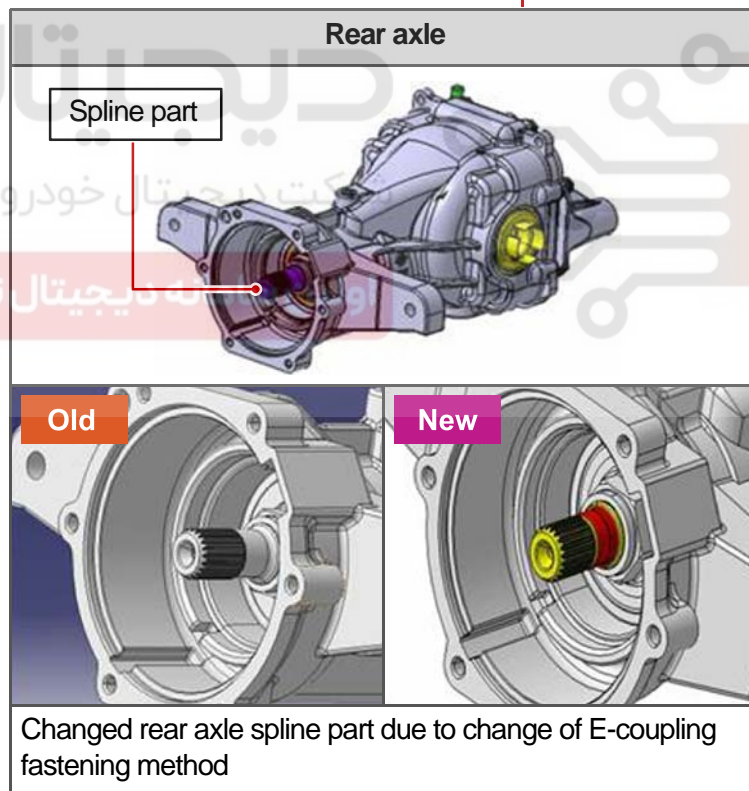
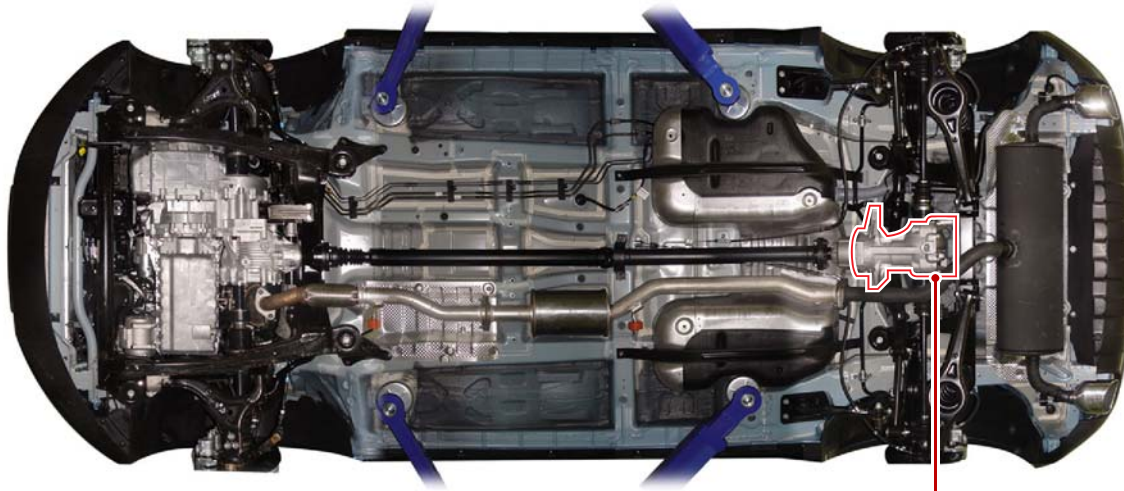

Modification basis	
Application basis	
Affected VIN	

OVERVIEW AND OPERATING PROCESS

1. COMPONENT

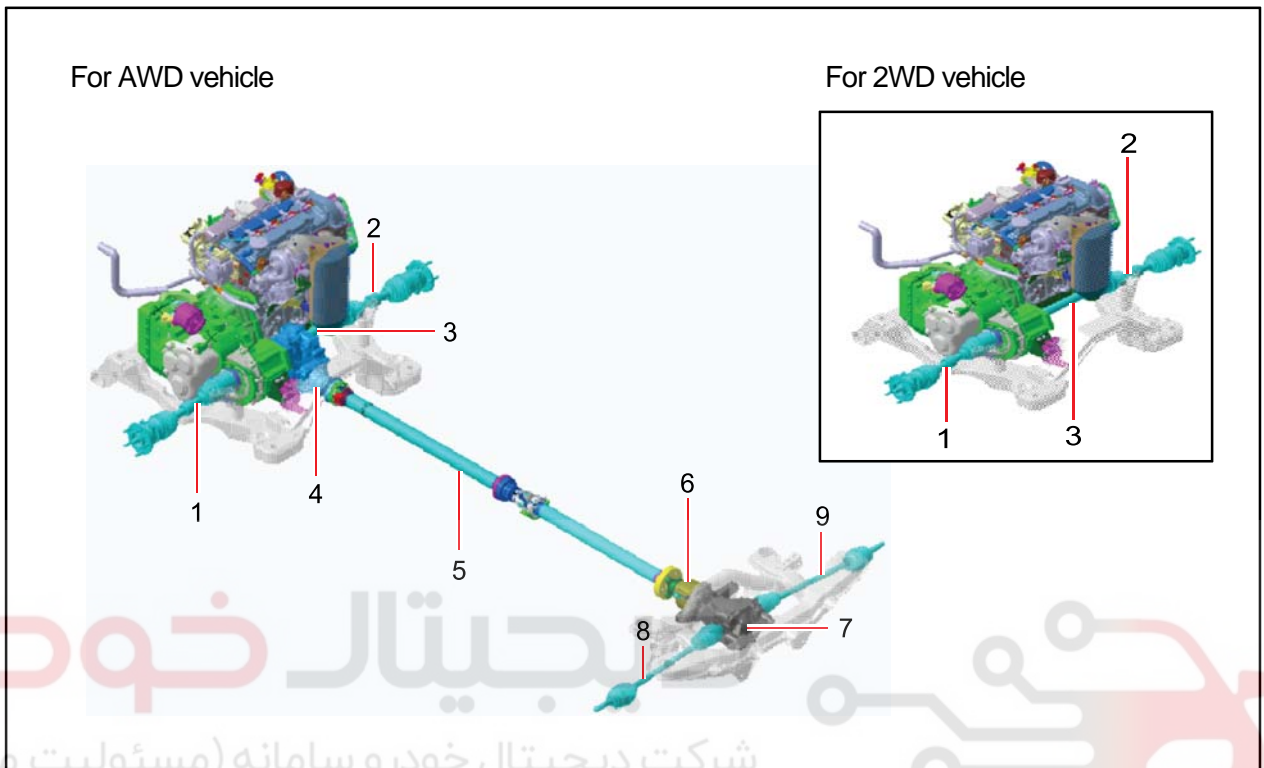

- | | |
|-----------------------------------|------------------------------------|
| 1. Front drive shaft (LH) | 6. E-coupling - 4WD |
| 2. Front drive shaft (RH) | 7. Rear differential carrier - 4WD |
| 3. Intermediate shaft | 8. Rear drive shaft (LH) - 4WD |
| 4. Power transfer unit(PTU) - 4WD | 9. Rear drive shaft (RH) - 4WD |
| 5. Propeller shaft - 4WD | |

Modification basis	
Application basis	
Affected VIN	

DRIVE SHAFT AND AXLE

KORANDO 2015.01

2. TORQUE STEER

Torque steer is a condition in which a vehicle pulls to either side because of an inequality of traction between the left and right driving wheels when a large torque is applied to the front wheel of a FWD or 4WD.

Especially for a FWD vehicle, this mechanical condition can cause the steering effect because of the output torque (rotational force) produced by the gyroscope.

This rotational force is due to the difference in distance between the left/right front wheels and the transaxle which leads to the change of the shaft bending angle.

To prevent this, the intermediate shaft, called Intermediate shaft, is employed on each side so that the bending angle and the length are kept constant.

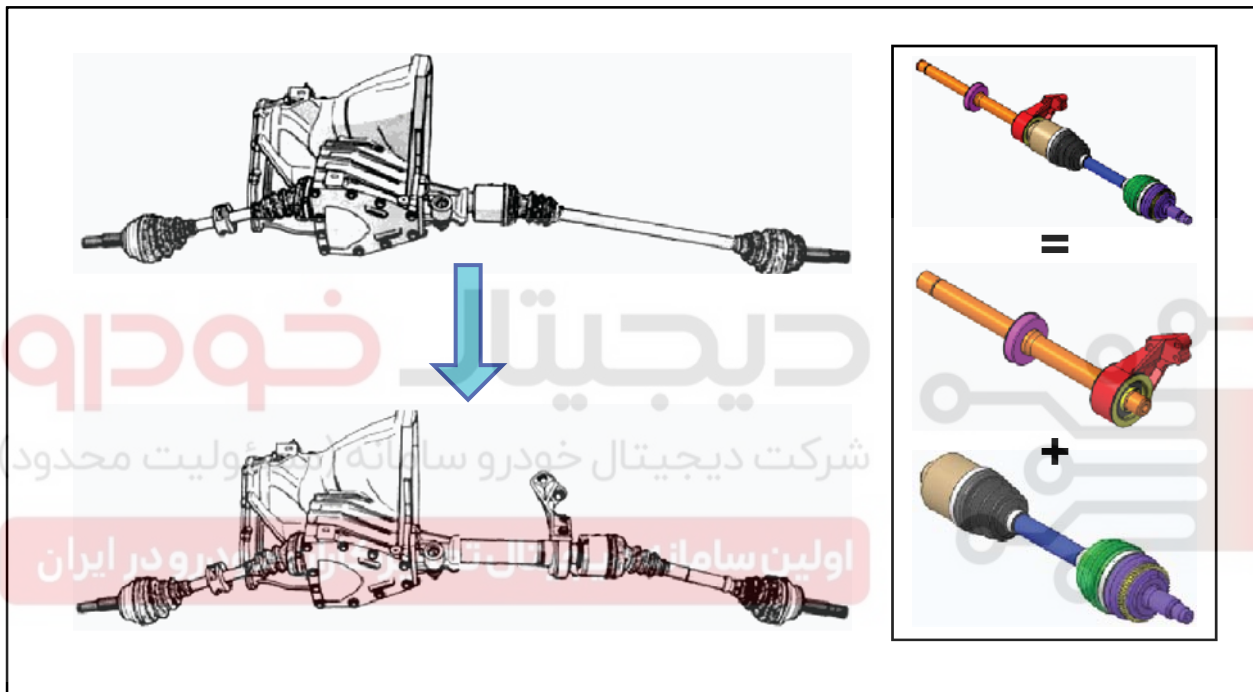

⚠ CAUTION

A gyroscope is a device for measuring or maintaining orientation, based on the principles of angular momentum. In essence, a mechanical gyroscope is a spinning wheel or disk whose axle is free to take any orientation. Although this orientation does not remain fixed, it changes in response to an external torque much less and in a different direction than it would without the large angular momentum associated with the disk's high rate of spin and moment of inertia. Since external torque is minimized by mounting the device in gimbals, its orientation remains nearly fixed, regardless of any motion of the platform on which it is mounted.

3. REAR AXLE

The rear axle installed in this car is a removable axle, called IRDA (Independent Rear Differential Axle). The rear differential carrier is installed directly on the sub frame, and there is an independent suspension that allows each wheel on the same axle to move vertically and independently of each other with the universal joint and the slip joint.



CHASSIS
GENERAL

DS16
SPEED

ASIN6
SPEED

HPT
6AT(6F2)

6-SPEED
MT

CLUTCH

PROPELLER

DRIVE
SHAFT

SUSPENSION

AWD

BRAKE
SYSTEM

ANTI-
LOCK

ELECTRONIC

POWER
STEERING

ELECTRIC
POWER

WHEEL &
TIRE

SUB
FRAME

Modification basis	
Application basis	
Affected VIN	

DRIVE SHAFT AND AXLE

KORANDO 2015.01

REMOVAL AND INSTALLATION

4110-01 TROUBLESHOOTING

Problem	Possible Cause	Action
Pulling to one side	Damaged ball joint in drive shaft	Replace
	Worn or stuck wheel bearing	Replace
	Defective front suspension or steering system	Adjust or replace
Shimmy	Worn, damaged or bent drive shaft	Replace
	Worn or deteriorated wheel bearing	Replace
Front wheel vibration	Improper wheel balance	Adjust or replace
	Defective front suspension or steering system	Adjust or replace
Abnormal noise	Worn, damaged or bent drive shaft	Replace
	Worn or damaged wheel bearing	Replace
	Loose nut	Adjust or replace
	Defective front suspension or steering system	Adjust or replace
	Insufficient oil	Add oil
	Worn or damaged differential gear or improper backlash	Adjust or replace

S.G.N.

4115-01 FRONT HUB AND KNUCKLE

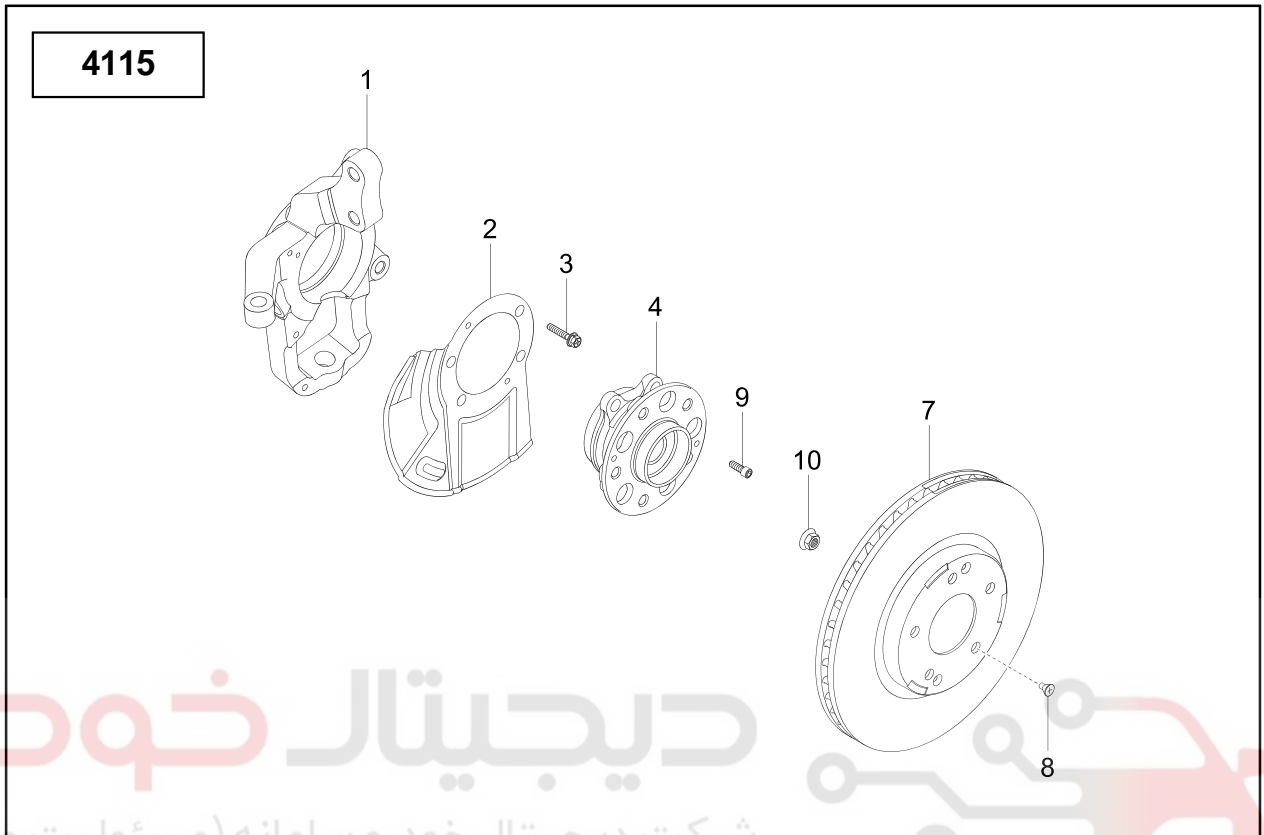

1. Front knuckle

2. Brake dust shield

3. Bolt

4. Hub

7. Brake disc

8. Screw

9. Bolt

10. Lock nut

Modification basis	
Application basis	
Affected VIN	

DRIVE SHAFT AND AXLE

KORANDO 2015.01

CHASSIS
GENERAL

DSI 6
SPEED

AISIN 6
SPEED

HPT
6AT(6F2)

6-SPEED
MT

CLUTCH

PROPELLER

DRIVE
SHAFT

SUSPENSION

AWD

BRAKE
SYSTEM

ANTI-
LOCK

ELECTRONIC

POWER
STEERING

ELECTRIC
POWER

WHEEL &
TIRE

SUB
FRAME

Preceding work

Loosen the front wheel bolts and lift up the vehicle with a lift by paying attention to the safety.



1. Remove the front tires.

CAUTION

Loosen the wheel bolts diagonally in 2 or 3 steps. Use the same manner to tighten the bolts.

Tightening torque 127.4 to 156.9 Nm

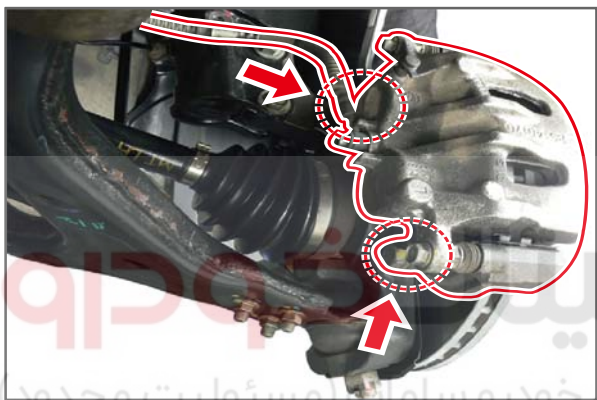

2. Unscrew the two mounting bolts (19 mm) on the brake caliper and tie the caliper to a suitable place with a wire.

Tightening torque 83.3 to 102.9 Nm



3. Unscrew the mounting bolts on the brake disc.



4. Remove the brake disc from the hub.

Modification basis	
Application basis	
Affected VIN	

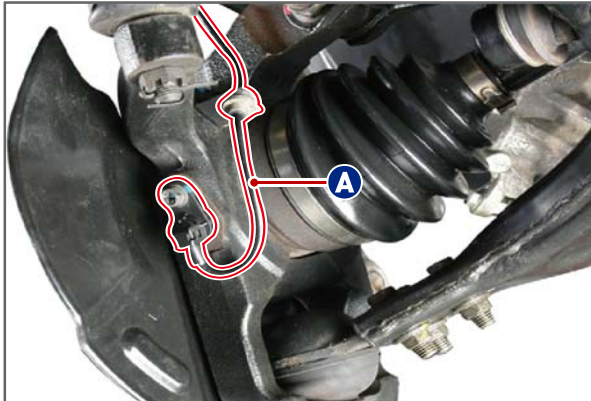

5. Unscrew the bolt (10 mm) and remove the front wheel speed sensor (A) from the knuckle.

Tightening torque 7.8 to 11.7 Nm



6. Release the locks and unscrew the hub nut (30 mm).

Tightening torque 245.0 to 343.0 Nm

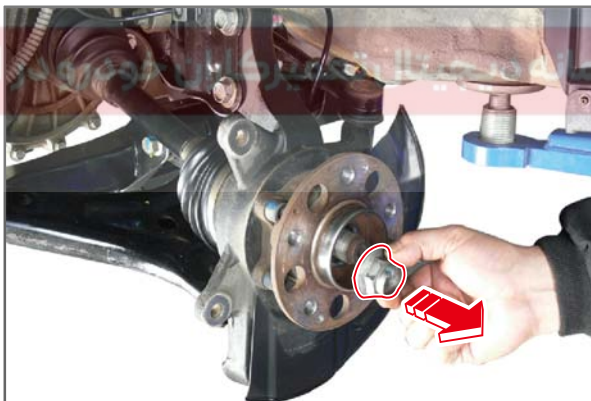

7. Remove the hub nut from the drive shaft.

CAUTION
Replace the hub nut with new one.



8. Unscrew four bolts (10 mm) from hub.

Tightening torque 107.8 to 127.4 Nm

Modification basis	
Application basis	
Affected VIN	



9. Remove the hub assembly and the brake dust shield from the knuckle.



- Appearance of hub assembly

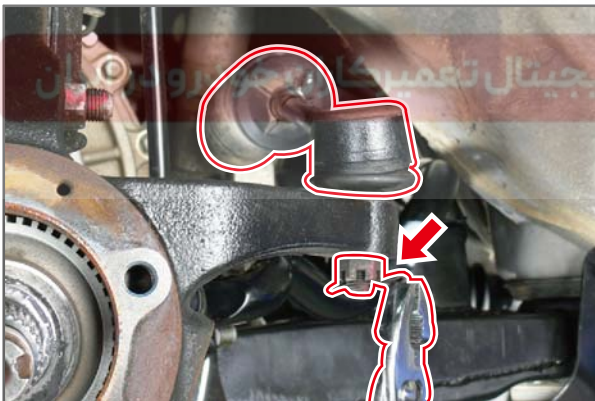

10. Remove the split pin inserted into the tie rod end of the steering gear linkage.

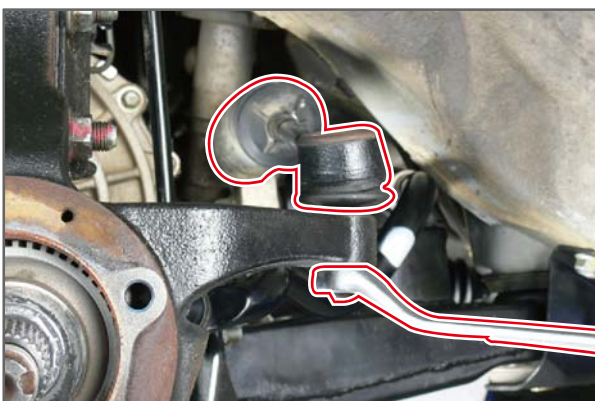

11. Unscrew the nut (17 mm) on the tie rod end.

Tightening torque 44.1 to 53.9 Nm

Modification basis	
Application basis	
Affected VIN	

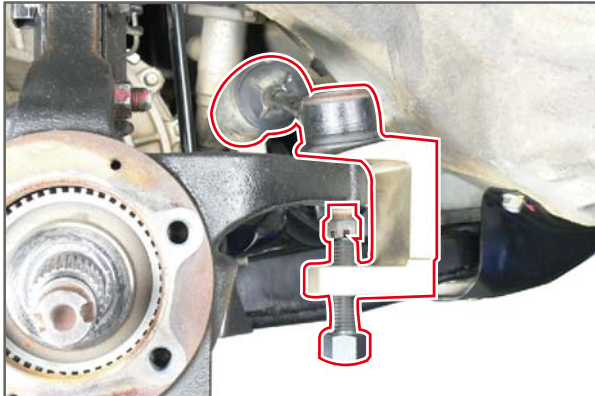

12.Remove the tie rod end from the knuckle with a special service tool.

CAUTION

Be careful not to damage the boot installed to the tie rod end.
If there is a fuel leak or damage, replace the tie rod end.

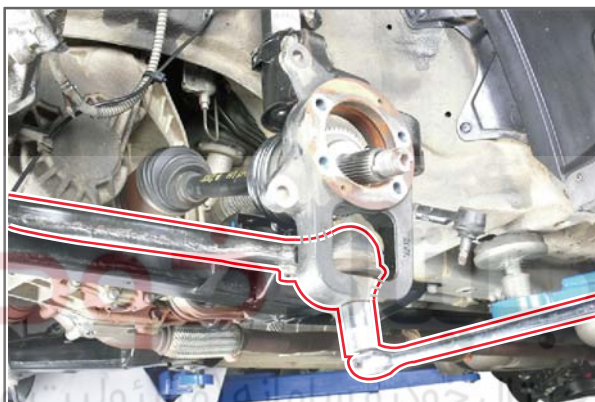

13.Remove the split pin and the mounting nut (24 mm) to remove the lower arm from the knuckle.

Tightening torque 117.6 to 156.8 Nm

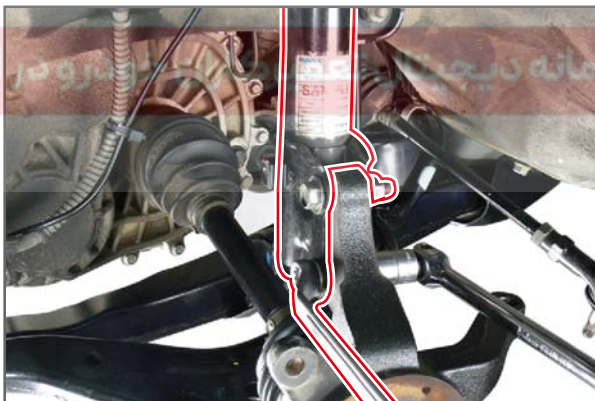

14.Unscrew the two mounting bolts (17 mm) on the shock absorber.

Tightening torque 137.2 to 156.8 Nm

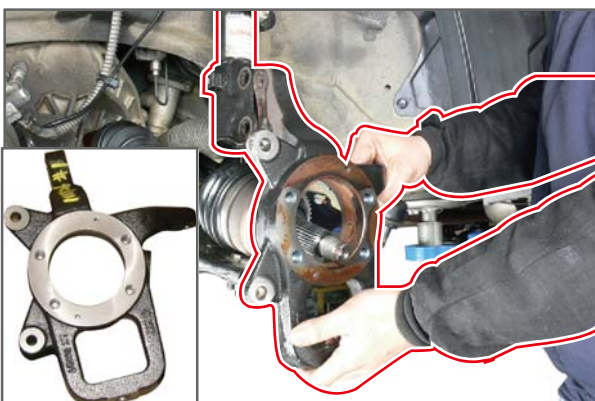

15.Remove the knuckle assembly.

Modification basis	
Application basis	
Affected VIN	

- CHASSIS GENERAL
- DSI 6 SPEED
- AI SIN 6 SPEED
- HPT 6AT(6F2)
- 6-SPEED MT
- CLUTCH
- PROPELLER
- DRIVE SHAFT
- SUSPENSION
- AWD
- BRAKE SYSTEM
- ANTI-LOCK
- ELECTRONIC
- POWER STEERING
- ELECTRIC POWER
- WHEEL & TIRE
- SUB FRAME



16. Install in the reverse order of removal.

CAUTION

Check the removed components for any defect and clean those components thoroughly. Install them by tightening the bolts and nuts to the specified torque.

دیجیتال خودرو

شرکت دیجیتال خودرو سامانه (مسئولیت محدود)

اولین سامانه دیجیتال تعمیرکاران خودرو در ایران



Modification basis	
Application basis	
Affected VIN	

S.G.N.

4221-01 REAR HUB AND KNUCKLE (FOR 4WD)

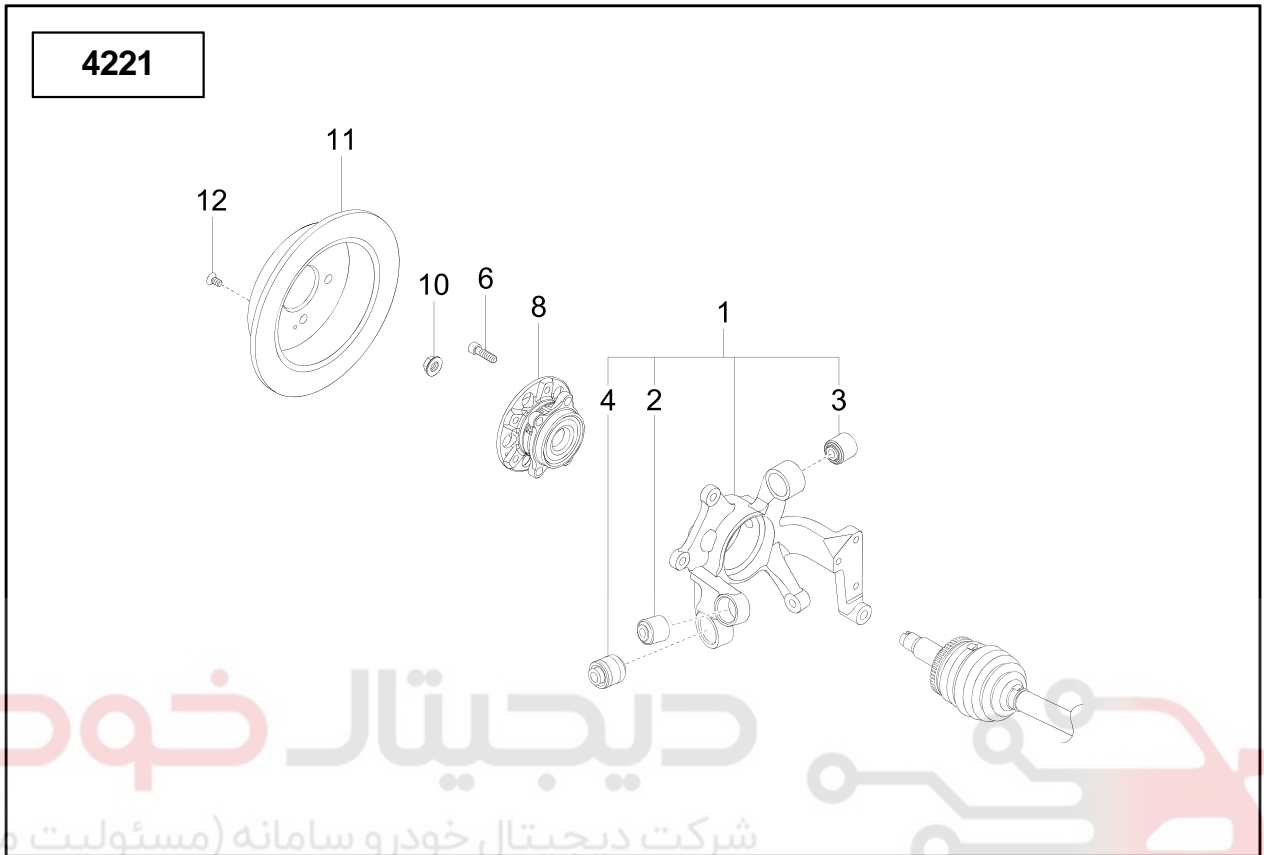

- 1. Rear knuckle assembly
- 2. Rubber bushing
- 3. Track rod bushing
- 4. Spring link ball joint assembly
- 6. Bolt
- 8. Hub assembly
- 10. Hub nut
- 11. Brake disc
- 12. Screw

Modification basis	
Application basis	
Affected VIN	

DRIVE SHAFT AND AXLE

KORANDO 2015.01

CHASSIS
GENERAL

DSI 6
SPEED

AISIN 6
SPEED

HPT
6AT(6F2)

6-SPEED
MT

CLUTCH

PROPELLER

DRIVE
SHAFT

SUSPENSION

AWD

BRAKE
SYSTEM

ANTI-
LOCK

ELECTRONIC

POWER
STEERING

ELECTRIC
POWER

WHEEL &
TIRE

SUB
FRAME

Preceding work

Loosen the rear wheel bolts and lift up the vehicle with a lift by paying attention to the safety.



1. Unscrew the wheel bolts and remove the rear tires.

CAUTION

Loosen the wheel bolts diagonally in 2 or 3 steps. Use the same manner to tighten the bolts.

Tightening torque 127.4 to 156.9 Nm

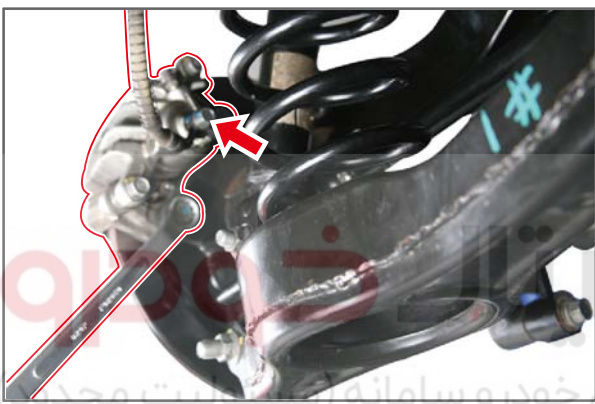

2. Unscrew the two mounting bolts (19 mm) on the brake caliper and tie the caliper to a suitable place with a wire.

Tightening torque 83.3 to 102.9 Nm



3. Unscrew the parking brake cable adjusting nut and remove the pin to disconnect the cable. Put the cable aside.

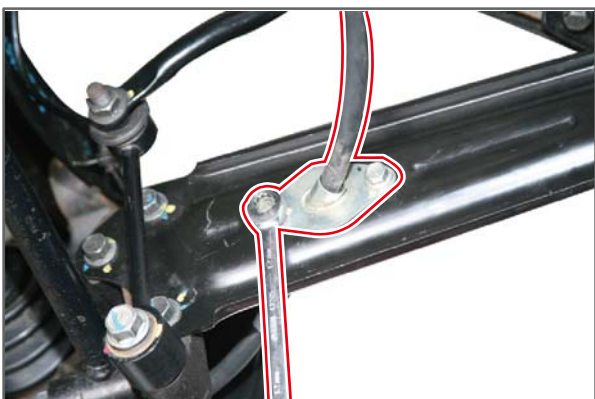

4. Unscrew the two mounting bolts (12 mm) from the trailing arm and disconnect the brake cable.

Tightening torque 9.8 to 12.7 Nm

Modification basis	
Application basis	
Affected VIN	

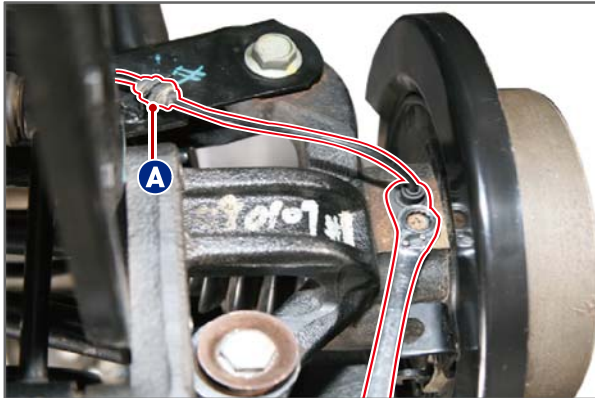

5. Disconnect the wheel speed sensor cable (A) and unscrew the wheel speed sensor mounting bolt (10 mm) to remove the wheel speed sensor from the knuckle.

Tightening torque 7.8 to 11.7 Nm



6. Unscrew the mounting bolts on the rear brake disc.



7. Remove the brake disc from the hub.



8. Unscrew the 4 hub bolts (10 mm) with the brake disc removed.

Tightening torque 107.8 to 127.4 Nm

Modification basis	
Application basis	
Affected VIN	



9. Undo caulking of the hub nut.



10. Unscrew the hub nut (30 mm).

Tightening torque 245.0 to 343.0 Nm

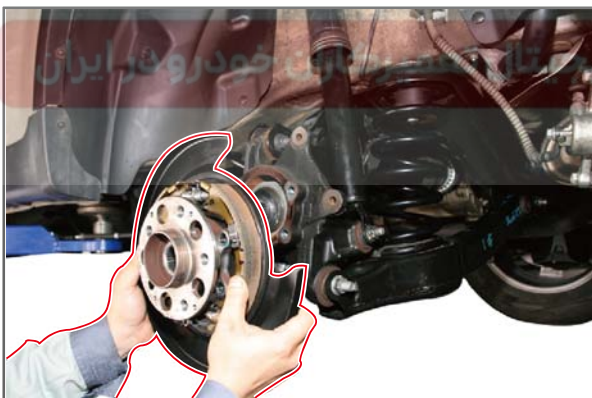

11. Remove the hub assembly.



12. Remove the disc plate and hub from the removed hub assembly.

Modification basis	
Application basis	
Affected VIN	



13. Place a jack under the lower arm.

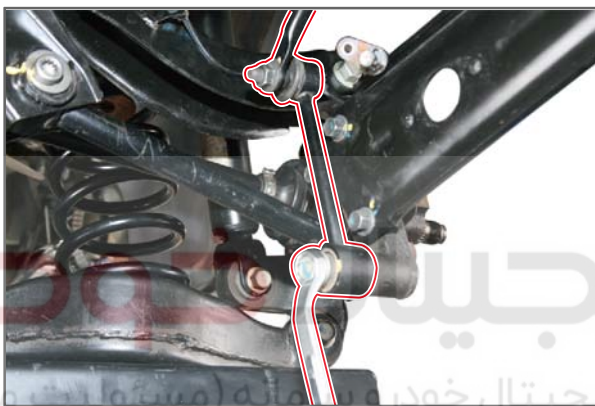

14. Unscrew the lower bolt (19 mm) on the stabilizer link.

Tightening torque 78.4 to 98.0 Nm

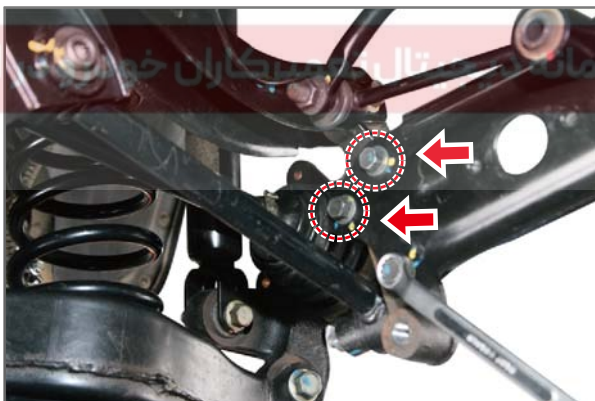

15. Unscrew the 3 trailing link bolts (14 mm) on the knuckle.

Tightening torque 49.0 to 68.6 Nm

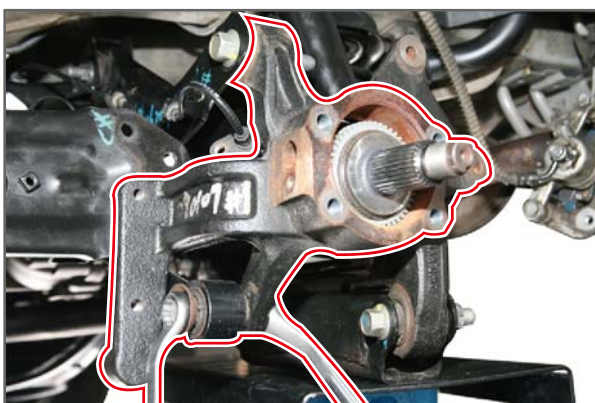

16. Unscrew the track rod mounting bolt/nut (19 mm) on the knuckle side.

Tightening torque 98.0 to 117.6 Nm

Modification basis	
Application basis	
Affected VIN	

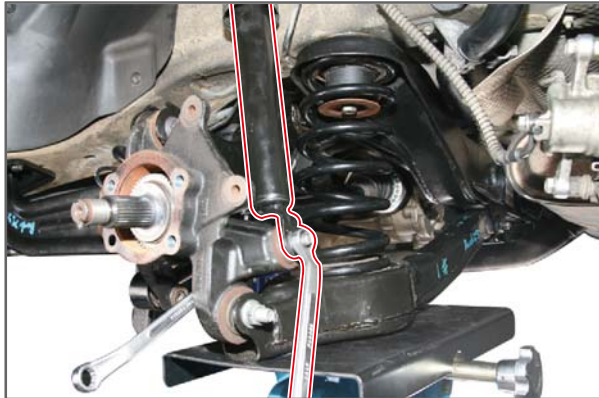

17. Unscrew the lower bolt/nut (19 mm) on the shock absorber, and remove the shock absorber from the knuckle.

Tightening torque 78.4 to 98.0 Nm

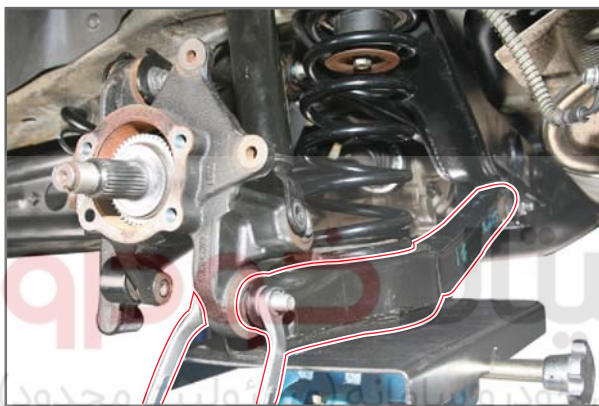

18. Unscrew the lower arm mounting bolt/nut (19 mm) on the knuckle side.

Tightening torque 137.2 to 156.8 Nm

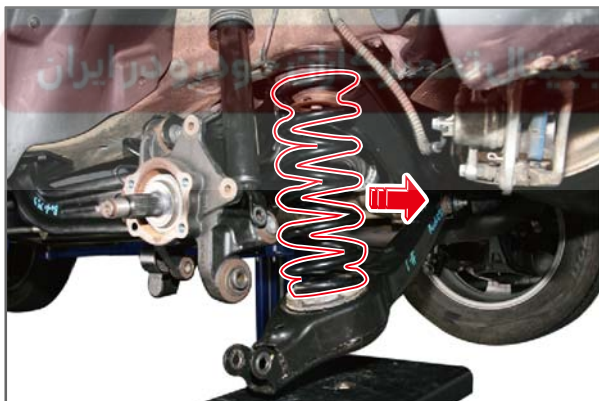

19. Remove the coil spring and the coil spring seat by slowly lowering the jack installed under the lower arm.

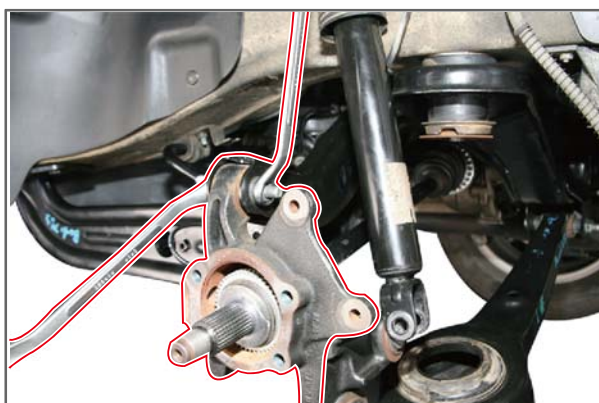

20. Unscrew the upper arm mounting bolt (17 mm) / nut (19 mm) on the knuckle side.

Tightening torque 98.0 to 117.6 Nm

Modification basis	
Application basis	
Affected VIN	

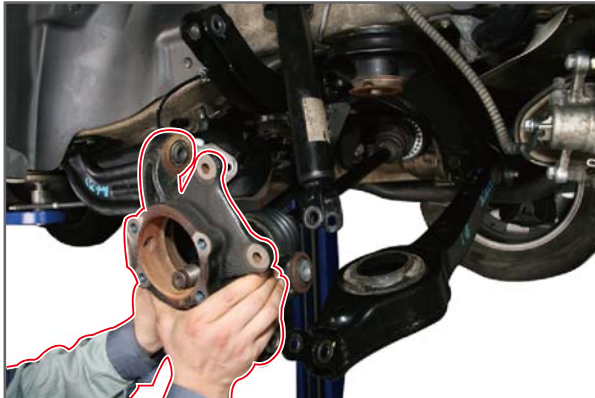

21.Remove the knuckle assembly.



22.Install in the reverse order of removal.

⚠ CAUTION

Tighten the bolts and the nuts to the specified torque. Check the removed components thoroughly to make sure that there are no abnormalities.

دیجیتال خودرو
شرکت دیجیتال خودرو سامانه (مسئولیت محدود)

اولین سامانه دیجیتال تعمیرکاران خودرو در ایران



CHASSIS
GENERAL

DSI 6
SPEED

AIN 6
SPEED

HPT
6AT(6F2)

6-SPEED
MT

CLUTCH

PROPELL
ER

DRIVE
SHAFT

SUSPENS
ION

AWD

BRAKE
SYSTEM

ANTI-
LOCK

ELECTRO
NIC

POWER
STEERIN

ELECTRI
C POWER

WHEEL &
TIRE

SUB
FRAME

Modification basis	
Application basis	
Affected VIN	

S.G.N. 4221-01 REAR HUB AND KNUCKLE (FOR 2WD)

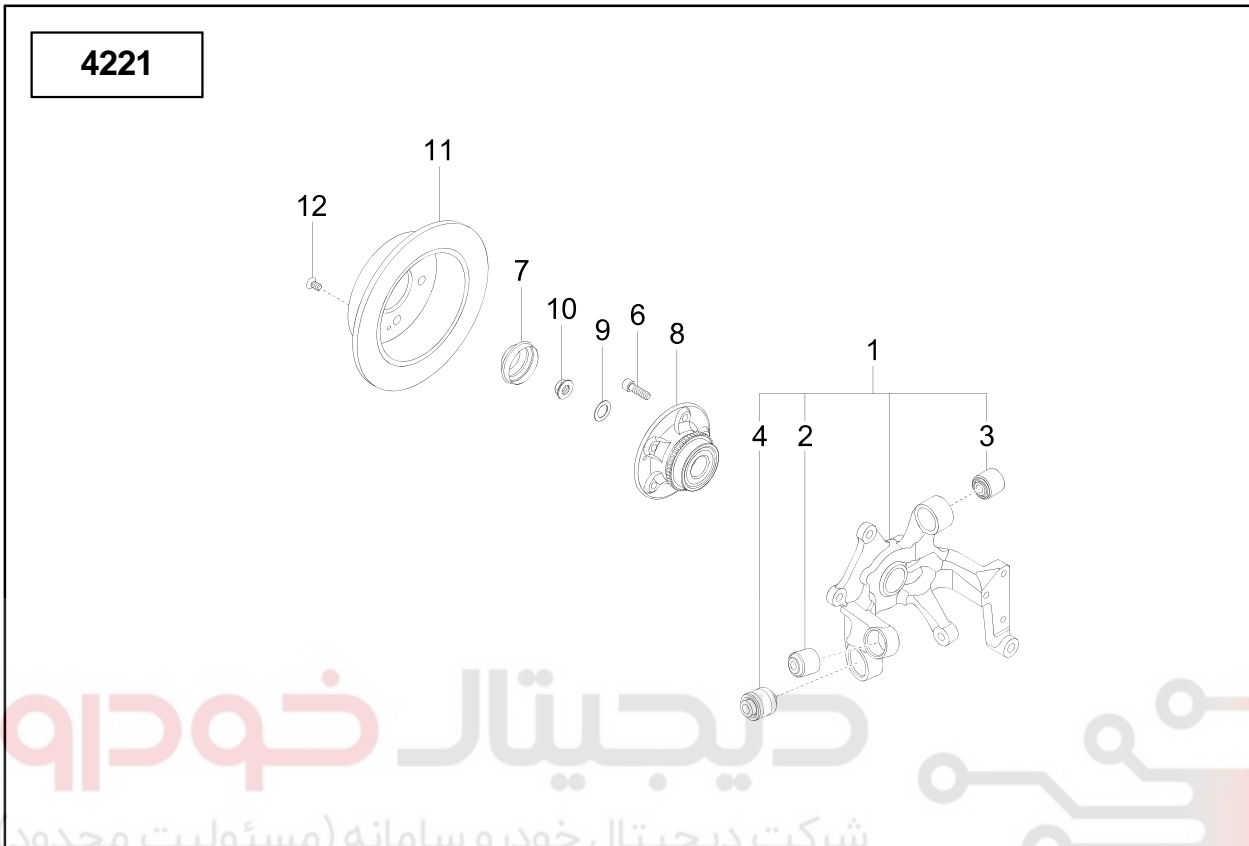

- 1. Rear knuckle assembly
- 2. Rubber bushing
- 3. Track rod bushing
- 4. Spring link ball joint assembly
- 6. Bolt
- 7. Hub nut cap
- 8. Hub assembly
- 9. Washer
- 10. Hub nut
- 11. Brake disc
- 12. Screw

Modification basis	
Application basis	
Affected VIN	



1. Remove the rear tires.

CAUTION

Loosen the wheel bolts diagonally in 2 or 3 steps. Use the same manner to tighten the bolts.

Tightening torque 127.4 to 156.9 Nm

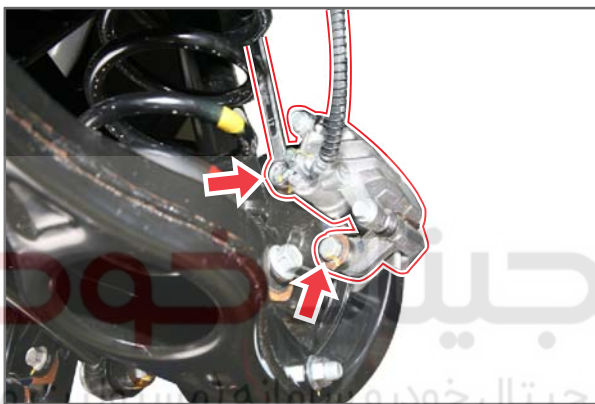

2. Unscrew the two mounting bolts (19 mm) on the brake caliper and tie the caliper to a suitable place with a wire.

Tightening torque 83.3 to 102.9 Nm

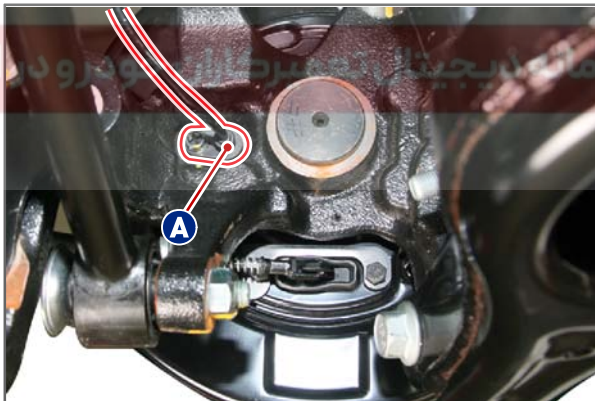

3. Unscrew the wheel speed sensor mounting bolt (10 mm) on the rear knuckle, and remove the wheel speed sensor (A) from the knuckle.

Tightening torque 7.8 to 11.7 Nm



4. Release the parking brake, then relieve the tension of the parking cable by unscrewing the mounting nut.

Modification basis	
Application basis	
Affected VIN	

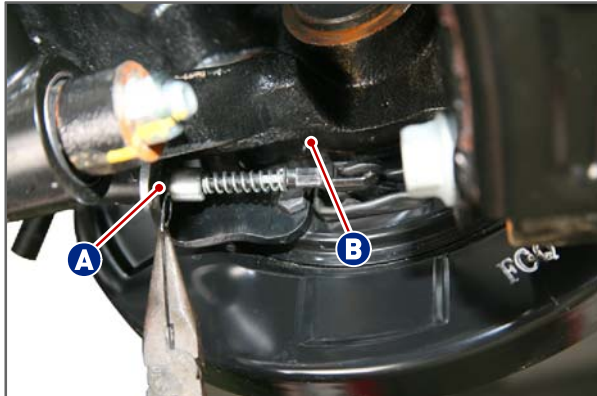

5. Remove the pin (A) from the brake back plate and put the cable (B) aside.

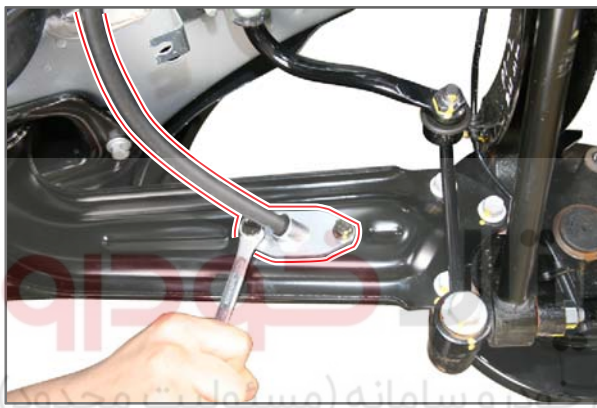

6. Unscrew the two brake cable bracket mounting bolts (12 mm) on the trailing arm to remove the brake cable.

Tightening torque 9.8 to 12.7 Nm



7. Remove the hub nut cap with a special service tool.

CAUTION
Apply sealant around the cap before installing the cap.



8. Unscrew the mounting bolts on the rear brake disc.

Modification basis	
Application basis	
Affected VIN	

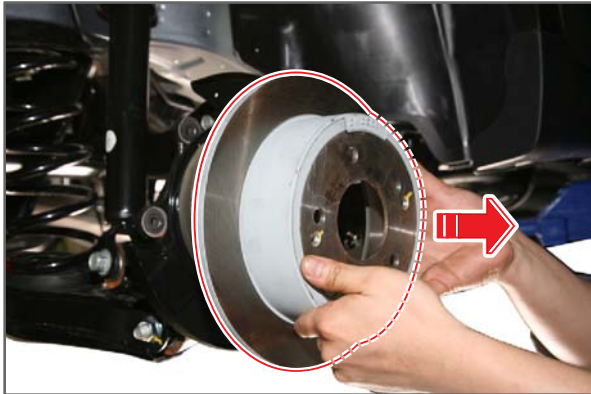

9. Remove the brake disc from the hub.



10. Undo caulking of the hub nut.



11. Unscrew the hub nut (30 mm).

Tightening torque 245.0 to 343.0 Nm

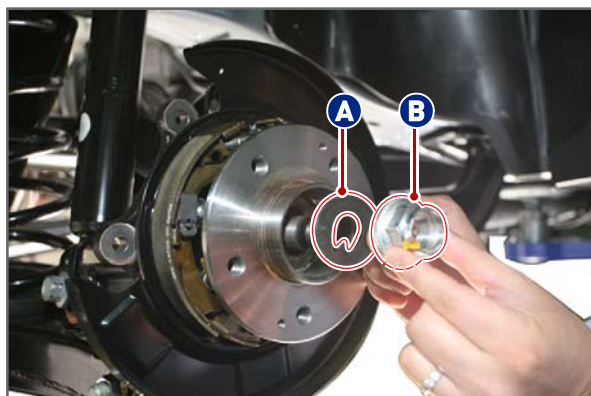

12. Remove the washer (A) and hub nut (B) from the hub.

Modification basis	
Application basis	
Affected VIN	

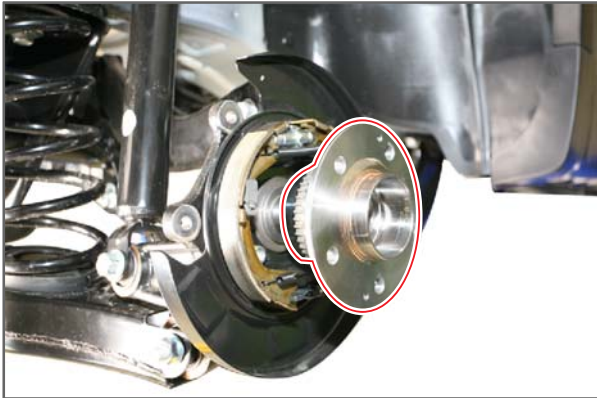

13.Remove the hub assembly.



14.Unscrew the 4 bolts (10 mm) from the rear disc brake.

Tightening torque 107.8 to 127.4 Nm

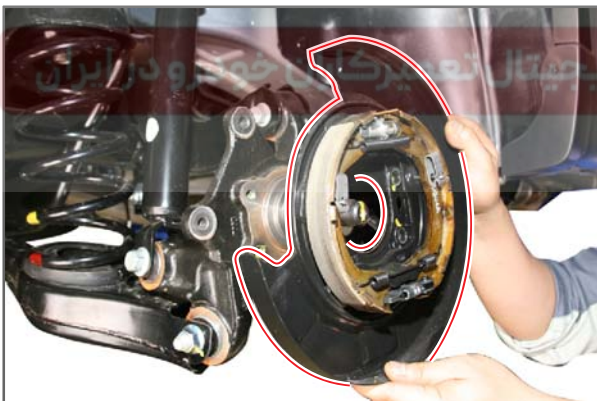

15.Remove the rear disc brake plate assembly.



16.Place a jack under the lower arm.

Modification basis	
Application basis	
Affected VIN	

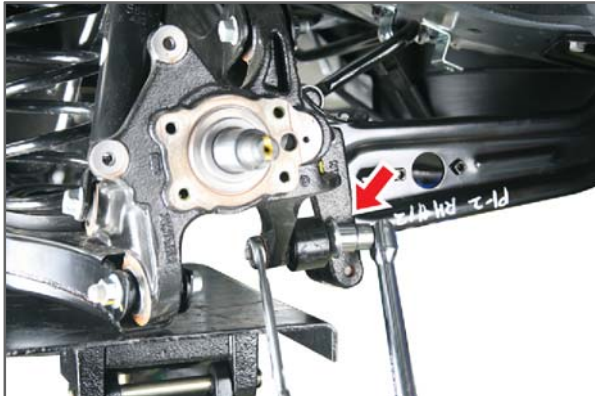

17. Unscrew the track rod bolt/nut (19 mm) on the knuckle side.

Tightening torque 98.0 to 117.6 Nm

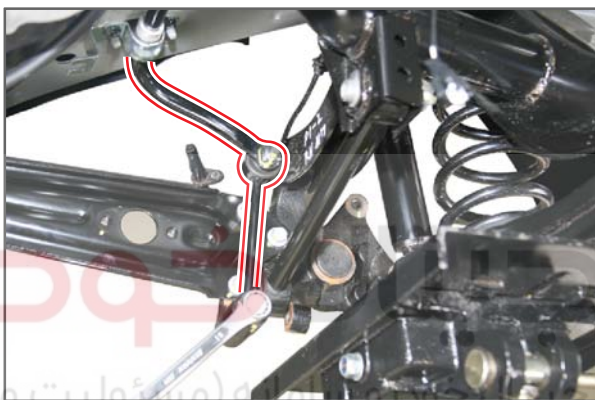

18. Unscrew the lower bolt (19 mm) on the stabilizer link.

Tightening torque 78.4 to 98.0 Nm



19. Unscrew the 3 trailing link bolts (14 mm) on the knuckle.

Tightening torque 49.0 to 68.6 Nm



20. Unscrew the lower bolt/nut (19 mm) and remove the shock absorber from the knuckle.

Tightening torque 78.4 to 98.0 Nm

Modification basis	
Application basis	
Affected VIN	

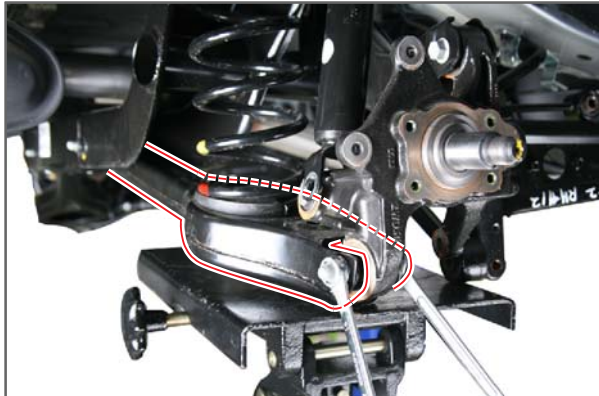

21. Unscrew the lower arm mounting bolt on the knuckle side.

Tightening torque 137.2 to 156.8 Nm

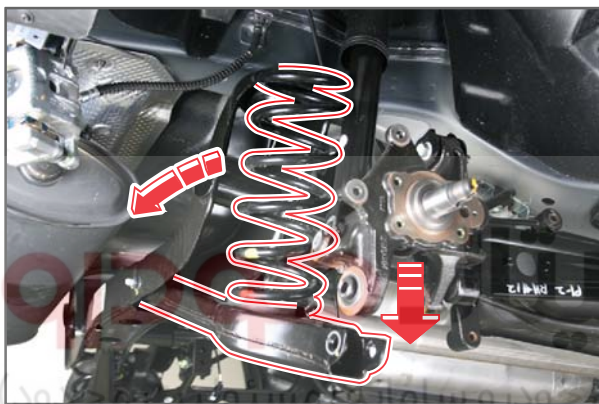

22. Remove the coil spring and the coil spring seat by slowly lowering the jack installed under the lower arm.

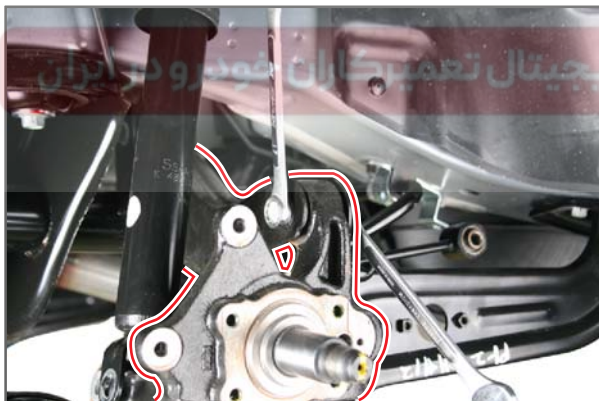

23. Unscrew the upper arm mounting bolt (17 mm) / nut (19 mm) on the knuckle side.

Tightening torque 98.0 to 117.6 Nm

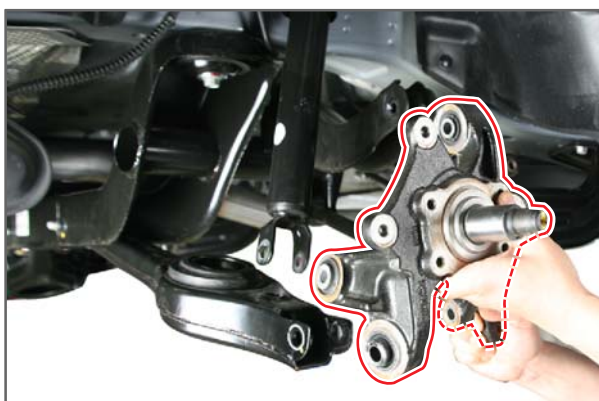

24. Remove the knuckle assembly.

Modification basis	
Application basis	
Affected VIN	



25. Install in the reverse order of removal.

⚠ CAUTION

Tighten the bolts and the nuts to the specified torque. Check the removed components thoroughly to make sure that there are no abnormalities.

دیجیتال خودرو

شرکت دیجیتال خودرو سامانه (مسئولیت محدود)

اولین سامانه دیجیتال تعمیرکاران خودرو در ایران



Modification basis	
Application basis	
Affected VIN	

DRIVE SHAFT AND AXLE

KORANDO 2015.01

S.G.N. 4110-01 FRONT DRIVE SHAFT (FOR 4WD)

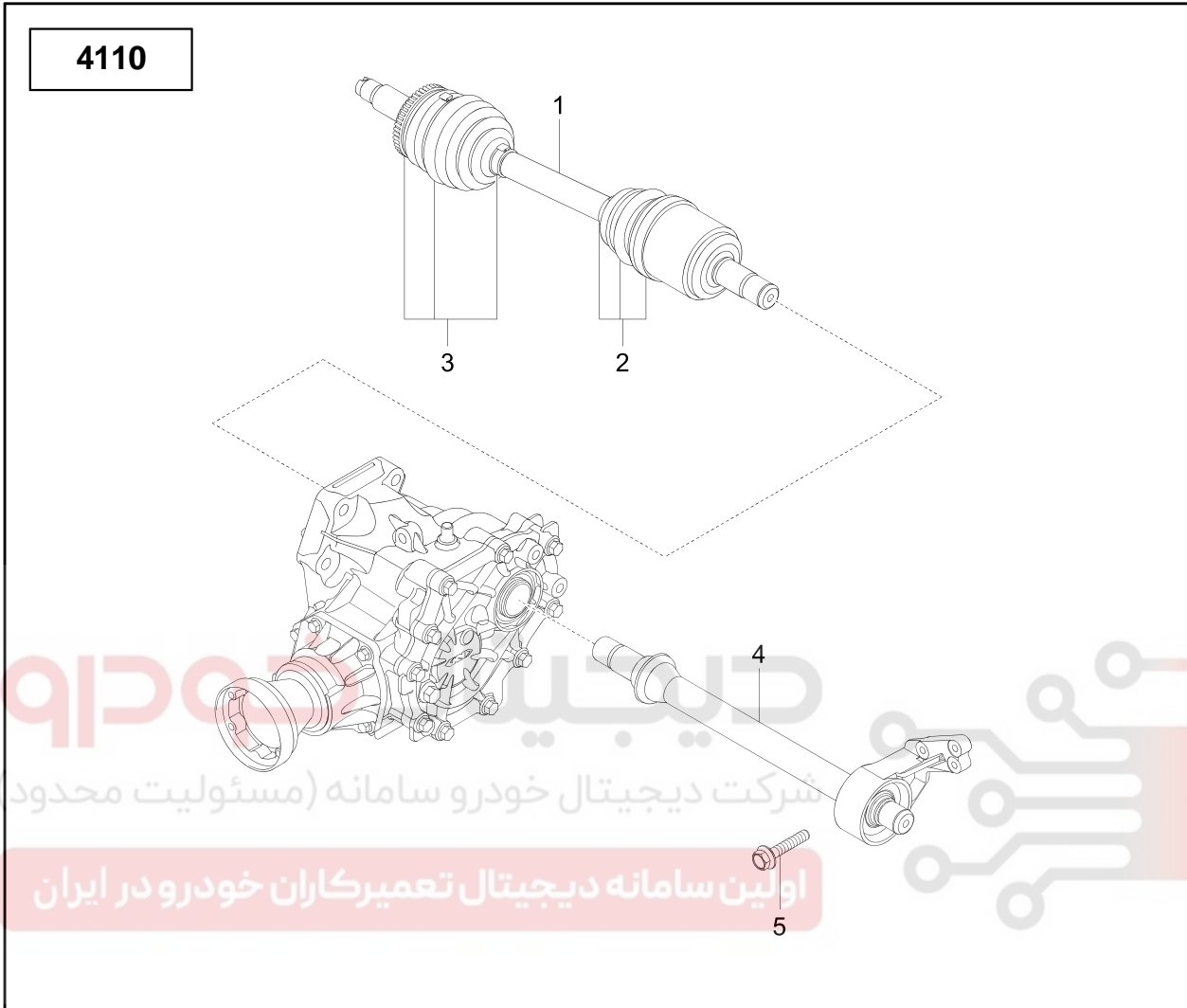

- 1. Front axle shaft assembly
- 2. Inner repair boot set (to axle)
- 3. Outer repair boot set (to wheel)

- 4. Intermediate shaft assembly
- 5. Bolt

Modification basis	
Application basis	
Affected VIN	

- Preceding work**
1. Loosen the front wheel bolts and lift up the vehicle with a lift by paying attention to the safety.
 2. Remove the front wheel tires.

CAUTION

Loosen the wheel bolts diagonally in 2 or 3 steps. Use the same manner to tighten the bolts.

Tightening torque 127.4 to 156.9 Nm

(1) Right drive shaft

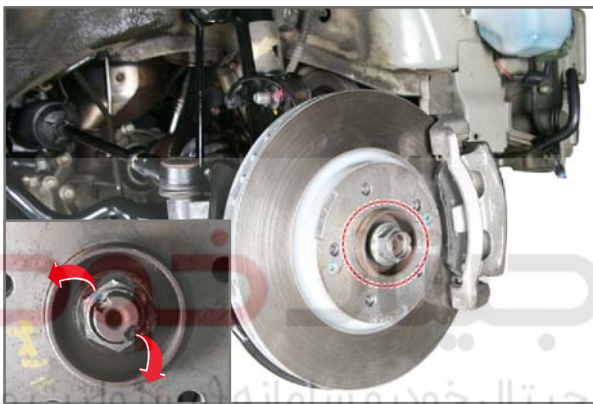

1. Undo caulking of the hub nut on the front drive shaft and unscrew the hub nut (30 mm).

Tightening torque 245.0 to 343.0 Nm

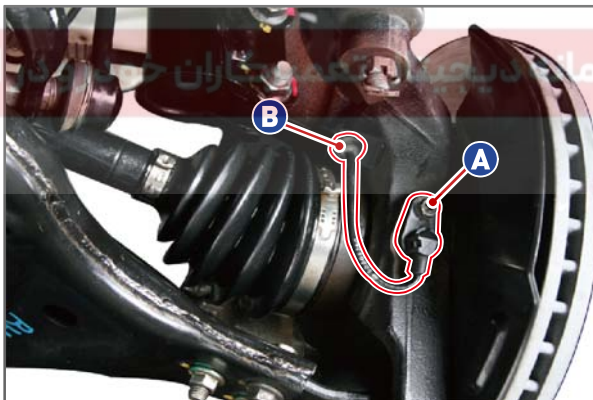

2. Unscrew the wheel speed sensor (A) mounting bolt (10 mm) to remove the wheel speed sensor, and disconnect the sensor cable (B) from the knuckle.

Tightening torque 7.8 to 11.7 Nm

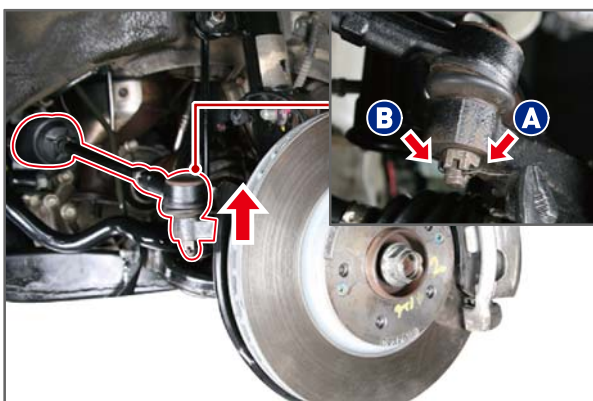

3. Remove the split pin (A) inserted into the tie rod end of the steering linkage and loosen the slot nut (B) to remove the tie rod end from the knuckle.

Tightening torque 44.1 to 53.9 Nm

Modification basis	
Application basis	
Affected VIN	

DRIVE SHAFT AND AXLE

KORANDO 2015.01

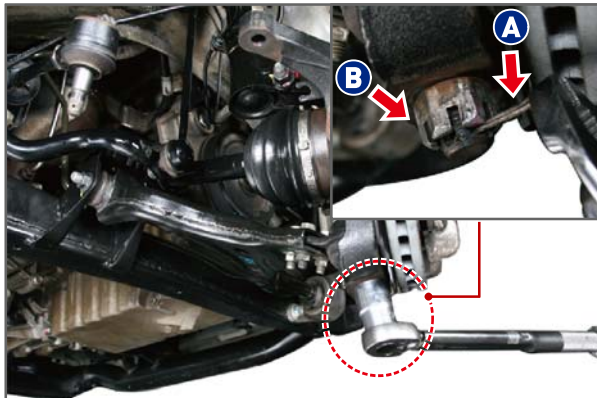

4. Remove the split pin (A) installed to the ball joint of the front lower arm and loosen the slot nut (B) to remove the ball joint of the knuckle.

Tightening torque 117.6 to 156.8 Nm

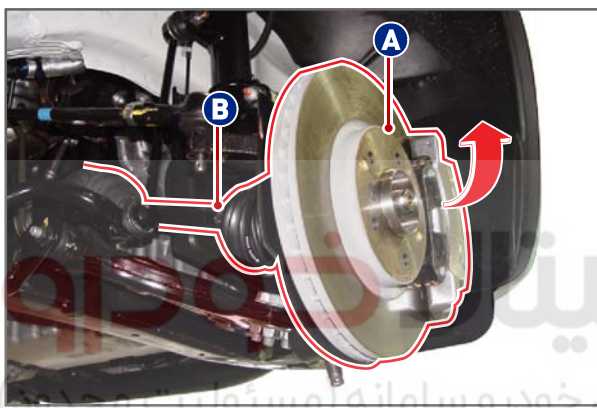

5. Remove the right drive shaft (B) from the transaxle by lifting up the wheel disc assembly (A).

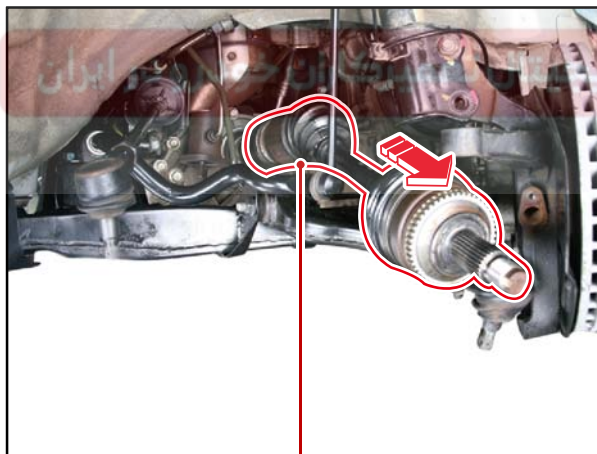

6. Remove the drive shaft (A) from the intermediate shaft (B).

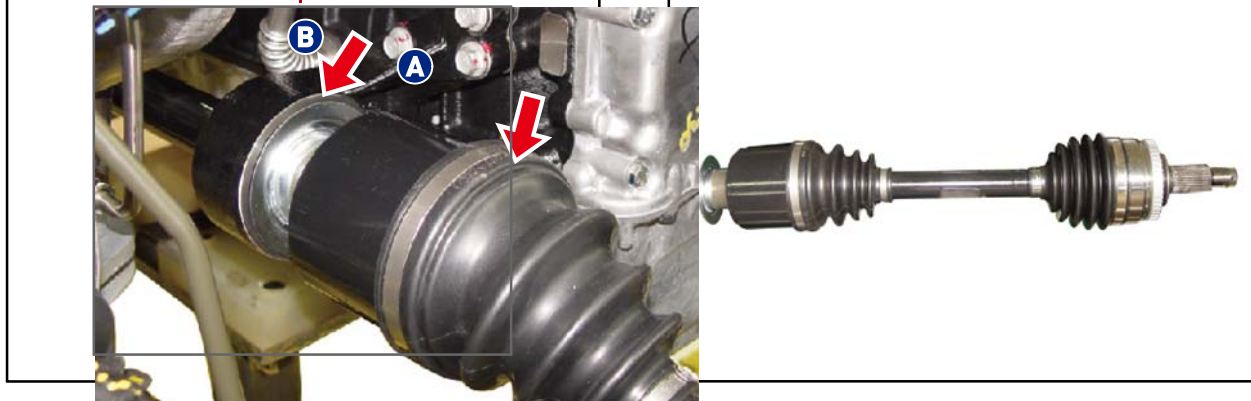

DRIVE SHAFT AND AXLE

KORANDO 2015.01

Modification basis	
Application basis	
Affected VIN	

7. Unscrew three bolts (12 mm) from the intermediate shaft bracket.

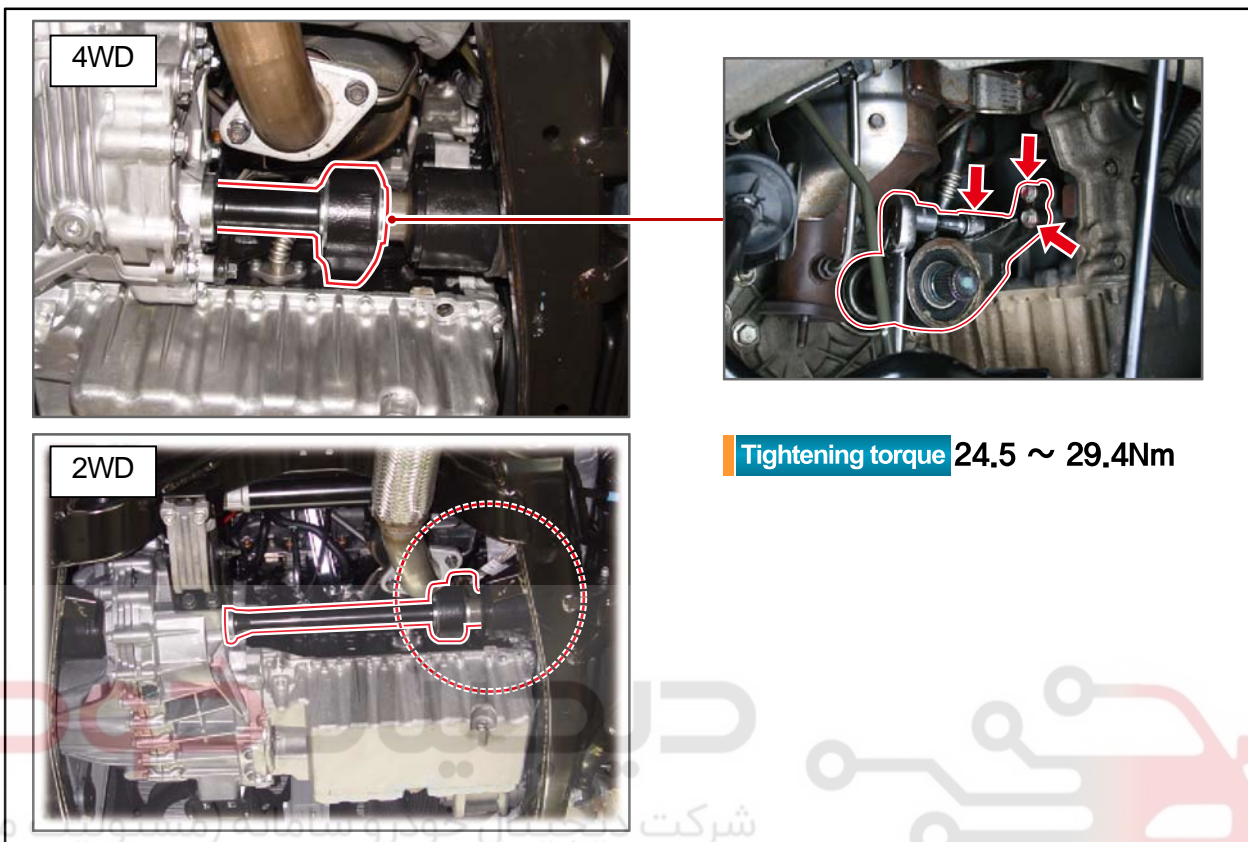

Tightening torque 24.5 ~ 29.4Nm

8. Remove the intermediate shaft from the transaxle.



Modification basis	
Application basis	
Affected VIN	

8. Install in the reverse order of removal.

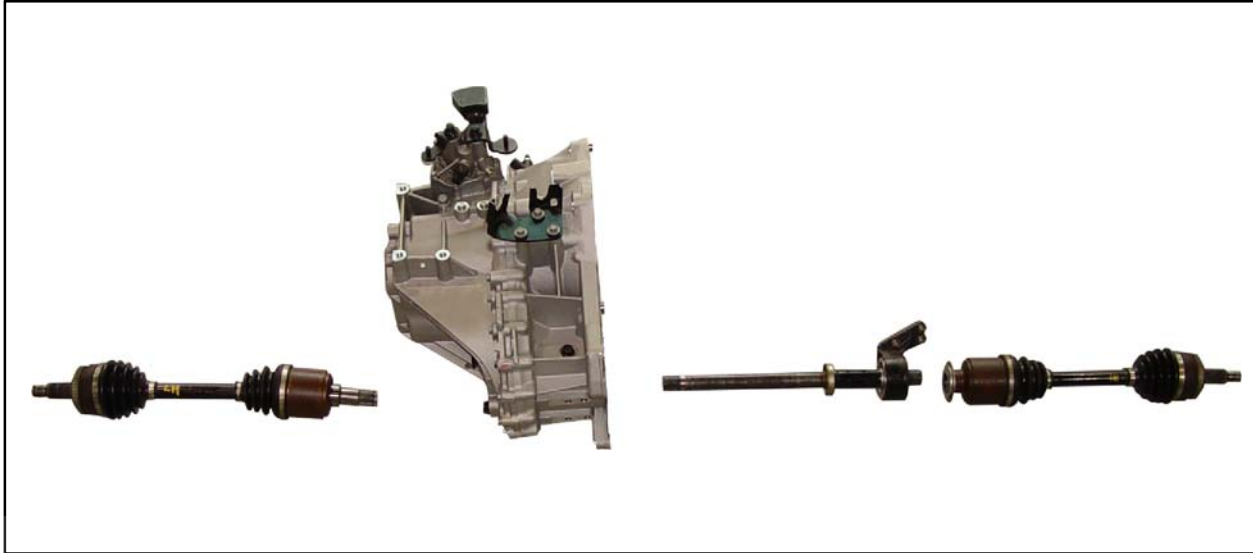

⚠ CAUTION

1. When installing, confirm that the drive shaft and the intermediate shaft are firmly installed to the transaxle. If not, the drive shaft will not work.
2. Be careful not to damage the oil seal when removing the drive shaft from the transaxle.
3. Plug the opening of the transaxle with the service cap to prevent entry of moisture and foreign matter.
4. Pulling the drive shaft with excessive force may cause displacement of the inner joint kit which leads to damage in the bearing or breakage in the boot.

Modification basis	
Application basis	
Affected VIN	

(2) Left drive shaft

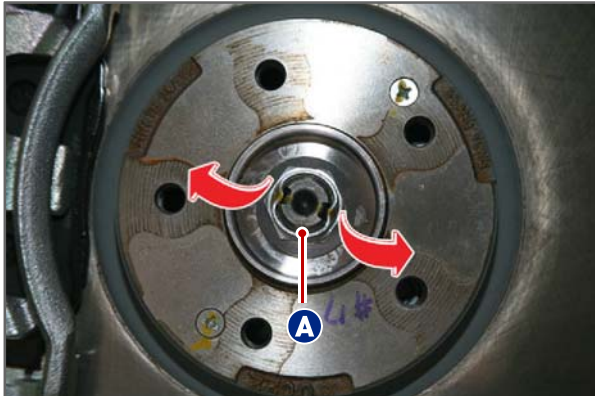

1. Release the locks and unscrew the hub nut (A, 30 mm).

Tightening torque 245 ~ 343Nm

CAUTION
Replace the hub nut with new one.

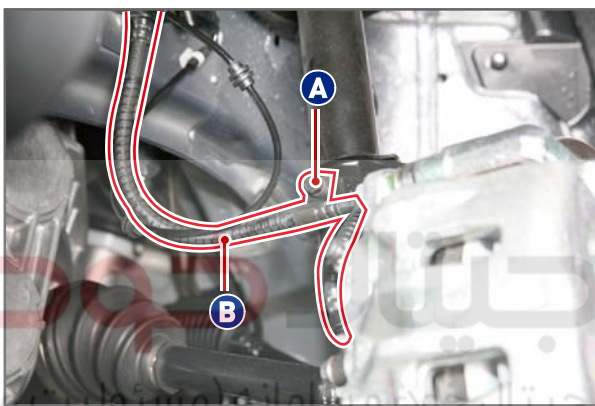

2. Unscrew the bolt (A, 12 mm) from the brake hose (B).

Tightening torque 9.8 ~ 12.8Nm

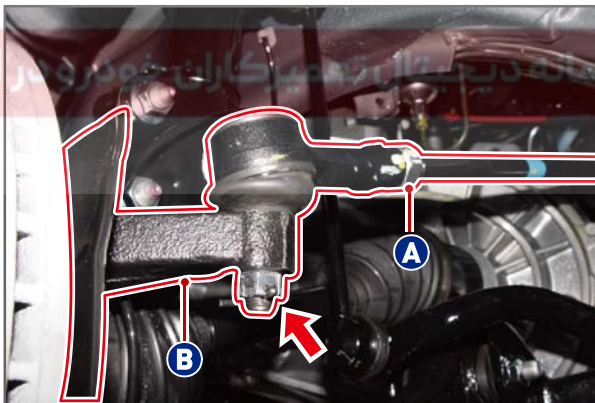

3. Pull out the clevis pin and unscrew the nut (17 mm) to remove the tie rod end (A) from the front knuckle (B).

CAUTION
Replace the clevis pin with new one.

Tightening torque 44.1 ~ 53.9Nm

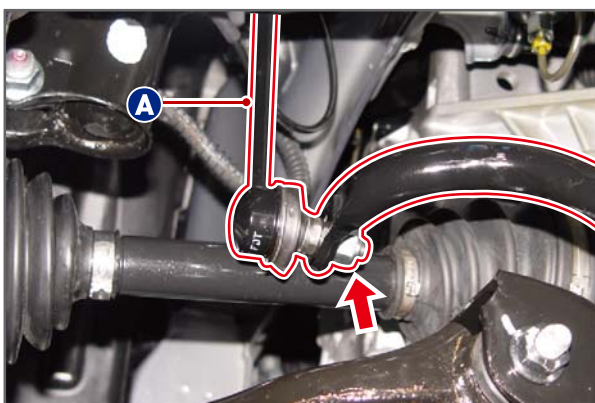

4. Unscrew the lower nut (17 mm) from the front stabilizer bar link (A).

Tightening torque 49.0 ~ 68.6Nm

Modification basis	
Application basis	
Affected VIN	

CHASSIS GENERAL
DSI 6 SPEED
AISIN 6 SPEED
HPT 6AT(6F2)
6-SPEED MT
CLUTCH
PROPELLER
DRIVE SHAFT
SUSPENSION
AWD
BRAKE SYSTEM
ANTI-LOCK
ELECTRONIC
POWER STEERING
ELECTRIC POWER
WHEEL & TIRE
SUB FRAME



5. Pull out the clevis pin (A) and unscrew the nut (24 mm) to remove the ball joint from the front knuckle.

Tightening torque 117.6 ~ 156.8Nm

CAUTION

Replace the clevis pin with new one.

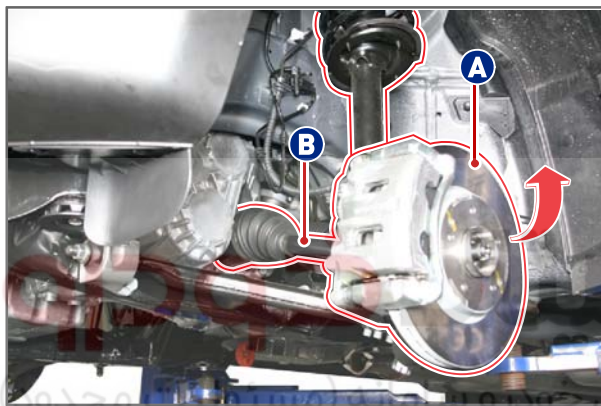

6. Remove the wheel disc assembly (A) from the drive shaft (B).

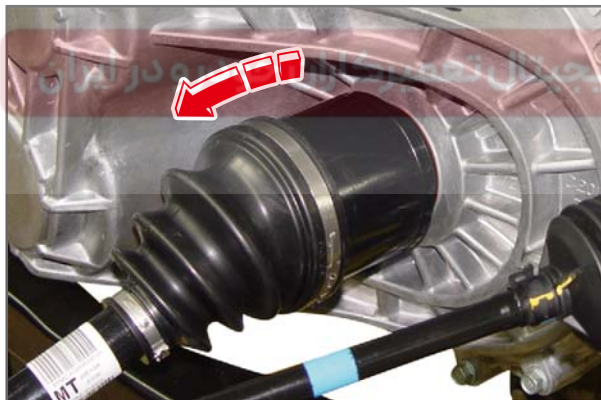

7. Remove the left front drive shaft from the transaxle.

CAUTION

1. When installing, confirm that the drive shaft and the intermediate shaft are firmly installed to the transaxle. If not, the drive shaft will not work.
2. Be careful not to damage the oil seal when removing the drive shaft from the transaxle. Plug the opening of the transaxle with the service cap to prevent entry of moisture and foreign matter.
3. Pulling the drive shaft with excessive force
4. may cause displacement of the inner joint kit which leads to damage in the bearing or breakage in the boot.



Modification basis	
Application basis	
Affected VIN	

S.G.N

4220-03

REAR DRIVE SHAFT (4WD)

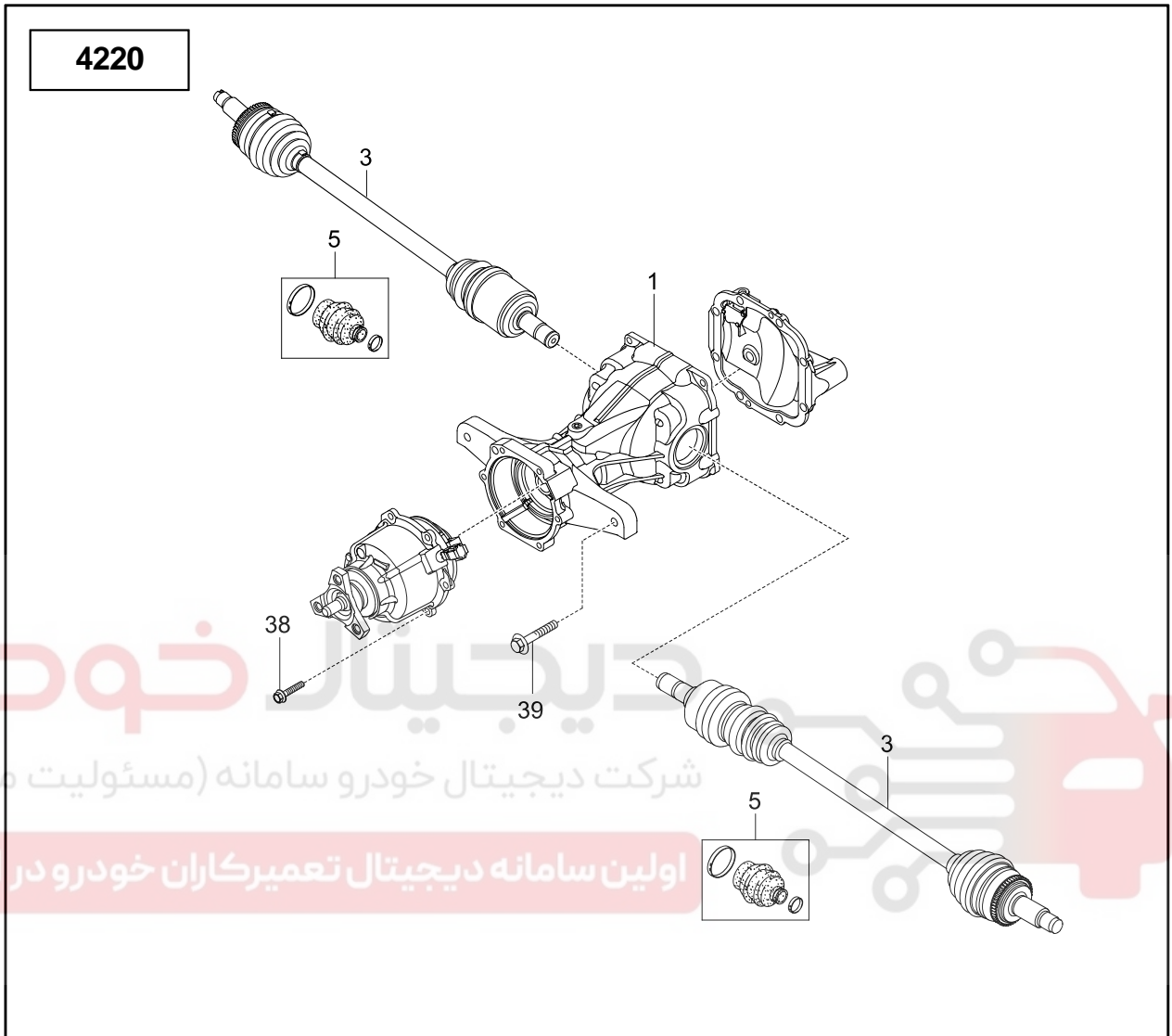

- 1. Rear axle assembly
- 3. Rear axle shaft assembly
- 5. Rear axle shaft repair kit

- 38. Flange bolt
- 39. Bolt

Modification basis	
Application basis	
Affected VIN	

DRIVE SHAFT AND AXLE

KORANDO 2015.01

CHASSIS
GENERAL

DSI 6
SPEED

AISIN 6
SPEED

HPT
6AT(6F2)

6-SPEED
MT

CLUTCH

PROPELLER

DRIVE
SHAFT

SUSPENSION

AWD

BRAKE
SYSTEM

ANTI-
LOCK

ELECTRONIC

POWER
STEERING

ELECTRIC
POWER

WHEEL &
TIRE

SUB
FRAME

- Preceding work**
1. Loosen the rear wheel bolts and lift up the vehicle with a lift by paying attention to the safety.
 2. Remove the rear tires.

⚠ CAUTION

Loosen the wheel bolts diagonally in 2 or 3 steps. Use the same manner to tighten the bolts.

Tightening torque 127.4 to 156.9 Nm

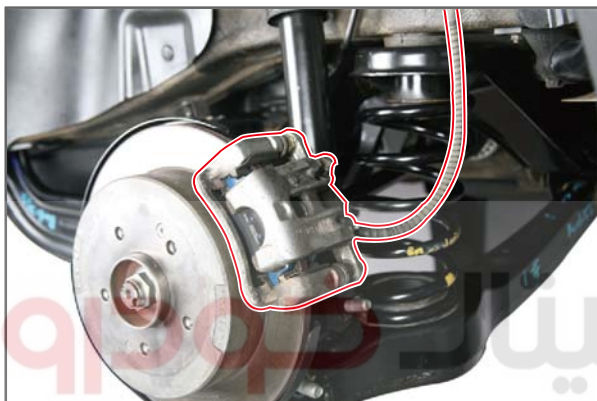

1. Remove the brake caliper.



2. Remove the mounting pin (A) from the brake back plate and put the cable aside.

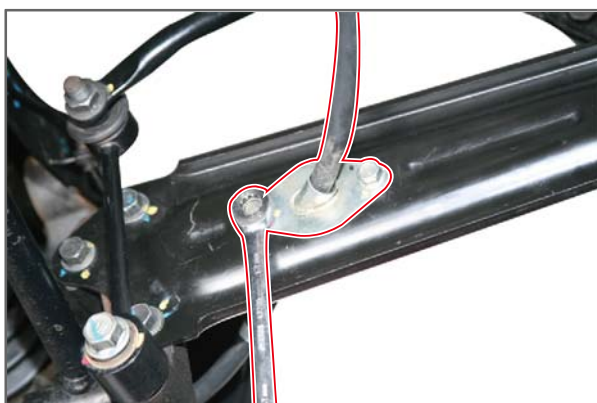

3. Unscrew the two bracket bolts (12 mm) from the trailing arm and disconnect the brake cable.

Tightening torque 9.8 to 12.7 Nm

Modification basis	
Application basis	
Affected VIN	

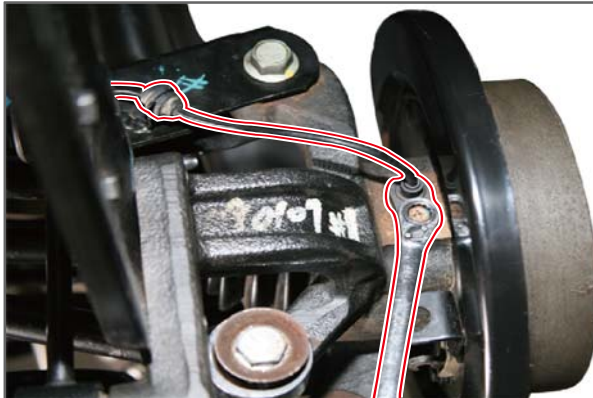

4. Unscrew the bolt (10 mm) to remove the wheel speed sensor from the knuckle.

Tightening torque 7.8 to 11.7 Nm



5. Unscrew the mounting screw and remove the brake disc.



6. Undo caulking of the hub nut and unscrew the hub nut (30 mm).

Tightening torque 245.0 to 343.0 Nm

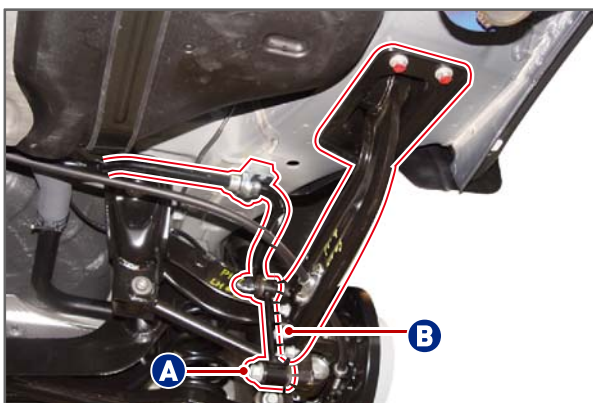

7. Put a jack under the lower arm and unscrew the lower mounting bolt (A) on the stabilizer bar link and the mounting bolt (B) on the trailing arm on the knuckle side.

Tightening torque for link lower mounting bolt (A) (19 mm x 1 EA)	78.4 to 98.0 Nm
Tightening torque for trailing arm mounting bolt (B) (14 mm x 3 EA)	49.0 to 68.6 Nm

Modification basis	
Application basis	
Affected VIN	

- CHASSIS GENERAL
- DSI 6 SPEED
- AISIN 6 SPEED
- HPT 6AT(6F2)
- 6-SPEED MT
- CLUTCH
- PROPELLER
- DRIVE SHAFT
- SUSPENSION
- AWD
- BRAKE SYSTEM
- ANTI-LOCK
- ELECTRONIC
- POWER STEERING
- ELECTRIC POWER
- WHEEL & TIRE
- SUB FRAME

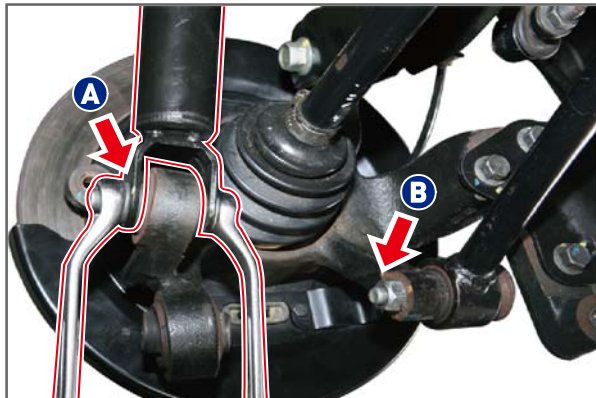

8. Unscrew the shock absorber lower mounting bolt (A) and the track rod mounting bolt (B) on the knuckle side.

Tightening torque for shock absorber lower mounting bolt (A) (17 mm x 1 EA)	78.0 to 98.0 Nm
Tightening torque for track rod mounting bolt at knuckle side (B) (19 mm x 1 EA)	98.0 to 117.6 Nm

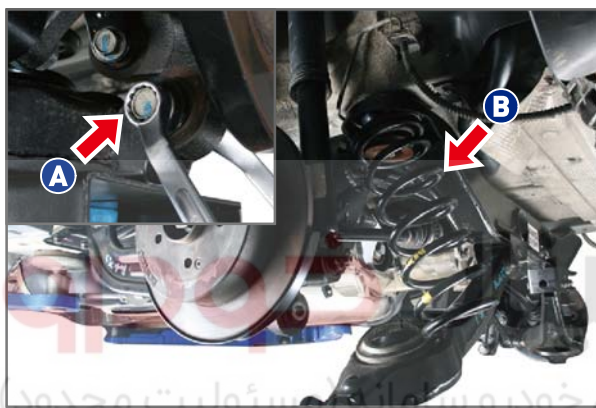

9. With the lower arm mounting bolt (A) on the knuckle side removed, remove the coil spring (B) by slowly lowering the axle jack.

Tightening torque for lower arm mounting bolt (A) on the knuckle side (19 mm x 1 EA)	137.2 to 156.8 Nm
--	-------------------

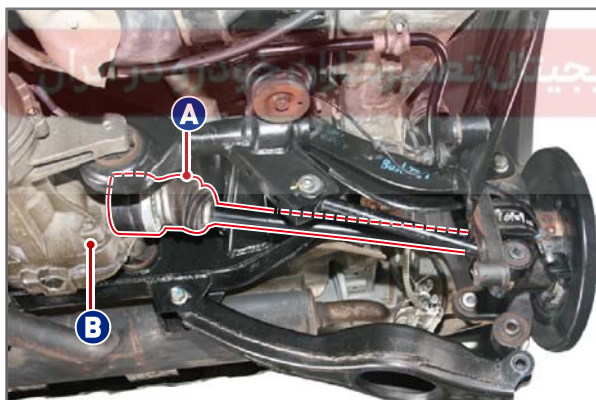

10. Separate the drive shaft (A) from the rear axle (B) using a screwdriver or equivalent.

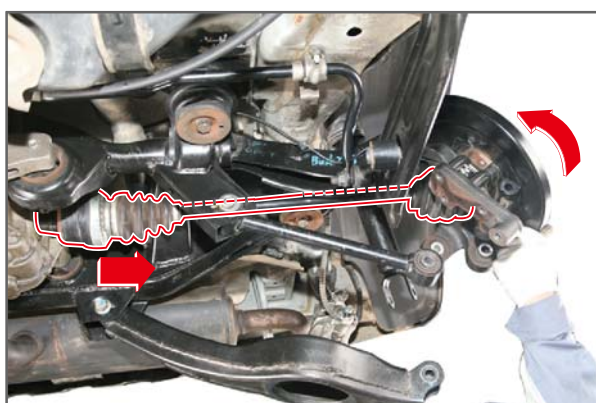

11. Remove the drive shaft from the rear axle by lifting up the knuckle assembly.

Modification basis	
Application basis	
Affected VIN	

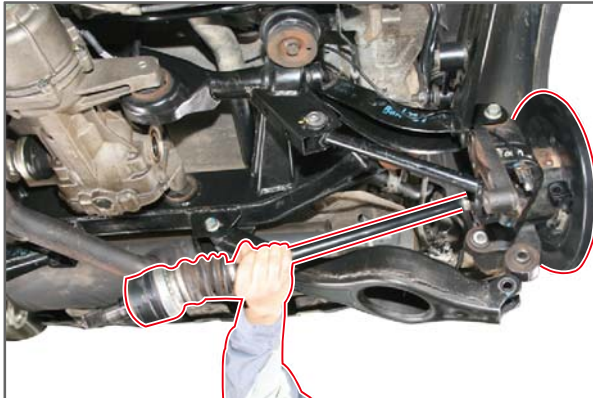

12. Remove the drive shaft.

13. Use the same procedures for the LH side and RH side. Install in the reverse order of removal.



⚠ CAUTION

1. When installing, confirm that the drive shaft is firmly installed to the rear axle.
2. Be careful not to damage the oil seal when removing the drive shaft from the rear axle.
3. Plug the opening of the rear axle with the service cap to prevent entry of moisture and foreign matter.
Pulling the drive shaft with excessive force may cause displacement of the inner joint kit which leads
4. to damage in the bearing or breakage in the boot.

Modification basis	
Application basis	
Affected VIN	

DRIVE SHAFT AND AXLE

KORANDO 2015.01

S.G.N.
4110-03 DRIVE SHAFT BOOT

**NOTE**

The replacement procedures are same for both front and rear drive shaft boots. The procedures listed below are for the front drive shaft.

Exploded view of front drive shaft (4WD)

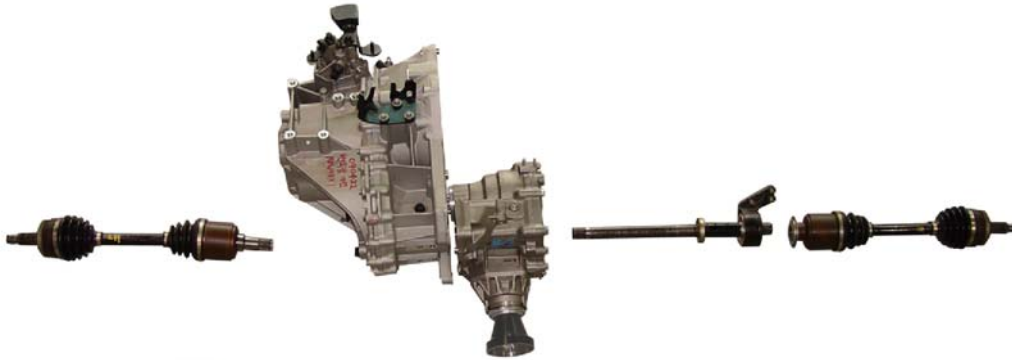

Exploded view of rear drive shaft (4WD ONLY)

**CAUTION**

1. The only grease that may be used for the joint of the drive shaft is special grease.
2. Always replace the used band for boot with a new one.

Modification basis	
Application basis	
Affected VIN	

1) Disassembly and Assembly

1. Disengage the both boot clamps of the inner shaft.

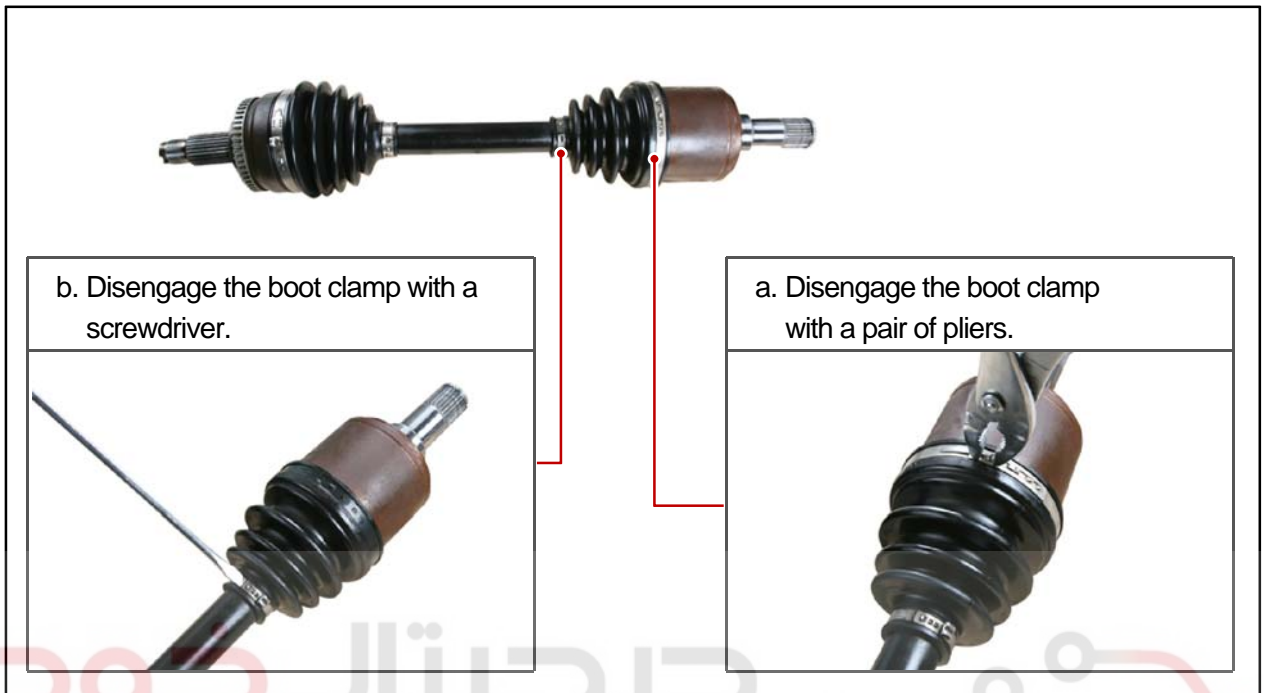

2. Separate the boot from the inner shaft.

CAUTION
Be careful not to damage the boot.

3. Remove the snap ring from the inner shaft at the axle side using a flat-bladed screwdriver.

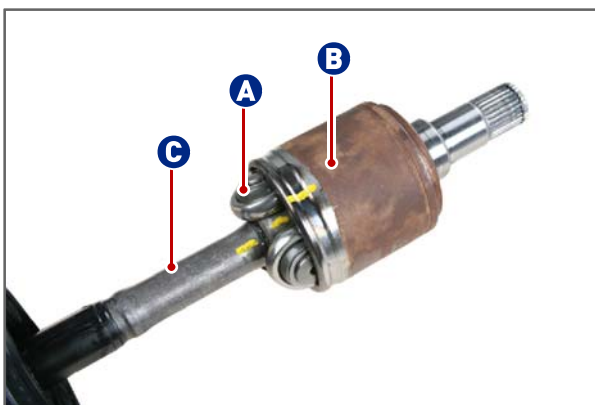

4. Put matchmarks on the trunnion assembly (A), the inner shaft (B) and the drive shaft (C).

Modification basis	
Application basis	
Affected VIN	



5. Remove the inner shaft and the trunnion cap from the drive shaft.



6. Remove the snap ring from the trunnion assembly using a pair of snap ring pliers.



7. Remove the trunnion assembly from the drive shaft.



8. Remove the inner boot from the drive shaft.

Modification basis	
Application basis	
Affected VIN	



9. Disengage the both boot clamps of the outer shaft.



10. Remove the outer boot from the drive shaft.



11. Clean the removed inner & outer shafts thoroughly and then fit the new boot. Fill it up with the specified special grease.



12. Install the boot to the outer (knuckle side) shaft and fit the new boot clamp.

Modification basis	
Application basis	
Affected VIN	

- CHASSIS GENERAL
- DSI 6 SPEED
- AISIN 6 SPEED
- HPT 6AT(6F2)
- 6-SPEED MT
- CLUTCH
- PROPELLER
- DRIVE SHAFT
- SUSPENSION
- AWD
- BRAKE SYSTEM
- ANTI-LOCK
- ELECTRONIC
- POWER STEERING
- ELECTRIC POWER
- WHEEL & TIRE
- SUB FRAME



- a. Engage the new clamp securely using a special tool.



13. Assemble the inner shaft and the boot.

- a. Fit the new clamp to the drive shaft and then the new boot.
b. Fit the new boot to the drive shaft in place and fasten with a clamp.



- c. Fill the inner shaft with a proper amount of specified grease.



- d. Install the inner shaft to the drive shaft and fill the new boot with a proper amount of grease.

Modification basis	
Application basis	
Affected VIN	



- e. Fit the new clamp to the inner shaft and fasten it firmly.

2) Check

Check the following items after replacing the drive shaft boot.

1. Check if the drive shaft moves freely in axial directions.
2. Check the spline of inner/outer shafts for wear.

دیجیتال خودرو
شرکت دیجیتال خودرو سامانه (مسئولیت محدود)

اولین سامانه دیجیتال تعمیرکاران خودرو در ایران



Modification basis	
Application basis	
Affected VIN	

S.G.N. **4220-01 REAR AXLE (FOR 4WD)**

- Preceding work**
1. Unscrew the wheel bolts and remove the rear tires.
 2. Remove the left and right rear drive shafts.
 3. Remove the drain plug and drain the axle oil completely.

1) Location

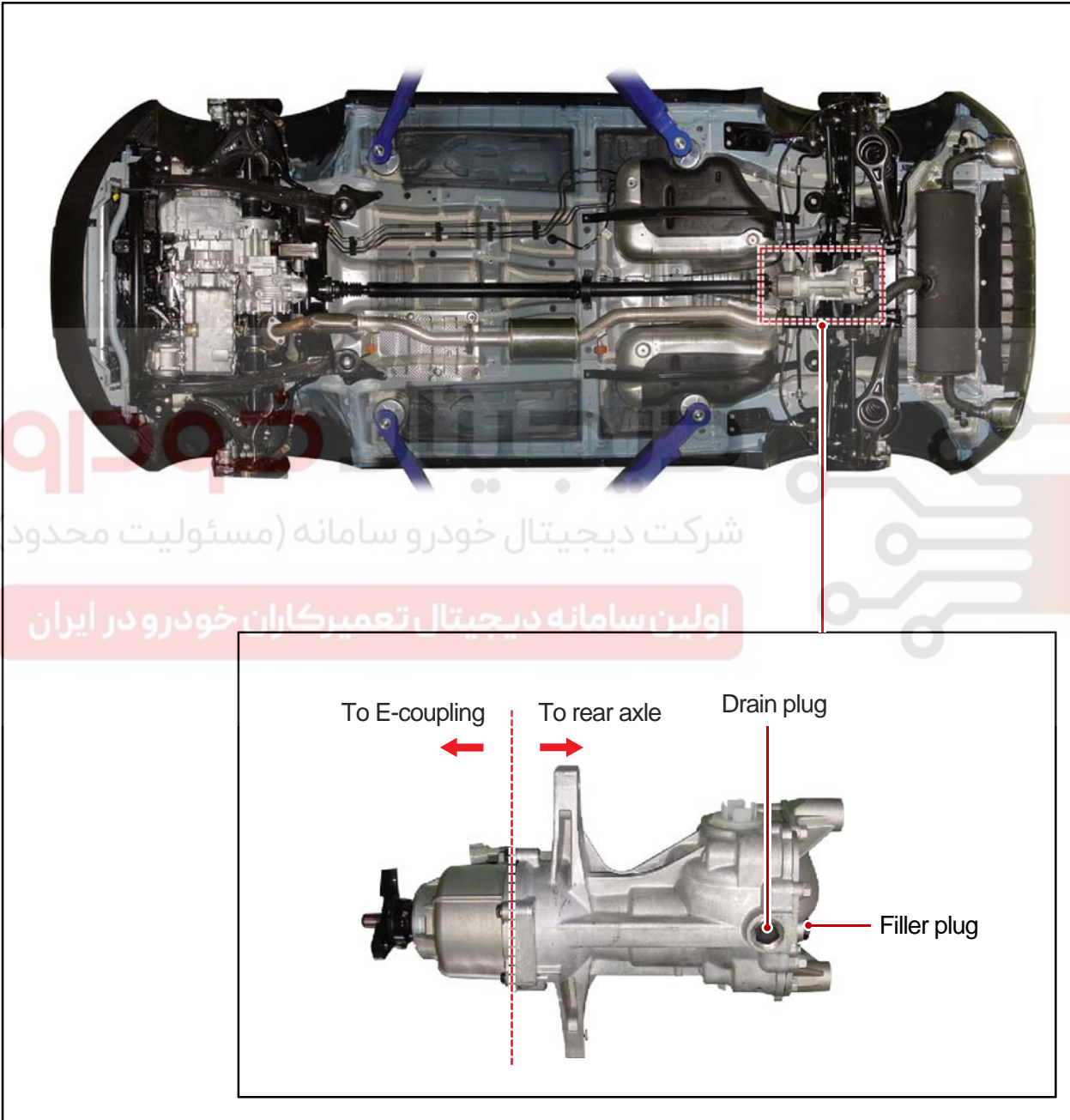

Modification basis	
Application basis	
Affected VIN	

► Removing E-coupling (up to and including Feb. 2014)



1. Unscrew the mounting bolt of the propeller shaft on the E-coupling, and secure the propeller shaft so that it cannot fall over. Refer to "Propeller Shaft" section for details of the procedure.

Tightening torque 39.2 to 49.0 Nm

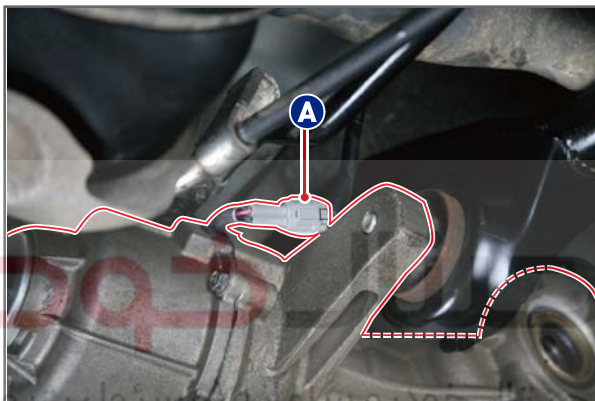

2. Disconnect the connector (A) of the E-coupling.



3. Unscrew the 6 mounting bolts (12 mm) on the E-coupling.

Tightening torque 19.6 to 24.5 Nm



4. Remove the E-coupling from the rear axle.

Modification basis	
Application basis	
Affected VIN	

- CHASSIS GENERAL
- DSI 6 SPEED
- AISIN 6 SPEED
- HPT 6AT(6F2)
- 6-SPEED MT
- CLUTCH
- PROPELLER
- DRIVE SHAFT
- SUSPENSION
- AWD
- BRAKE SYSTEM
- ANTI-LOCK
- ELECTRONIC
- POWER STEERING
- ELECTRIC POWER
- WHEEL & TIRE
- SUB FRAME

► Removing E-coupling (after Feb. 2014)



1. Unscrew the propeller shaft mounting bolt on the E-coupling and detach the propeller shaft. (See Propeller shaft section for more information)

Tightening torque 39.2 ~ 49.0Nm

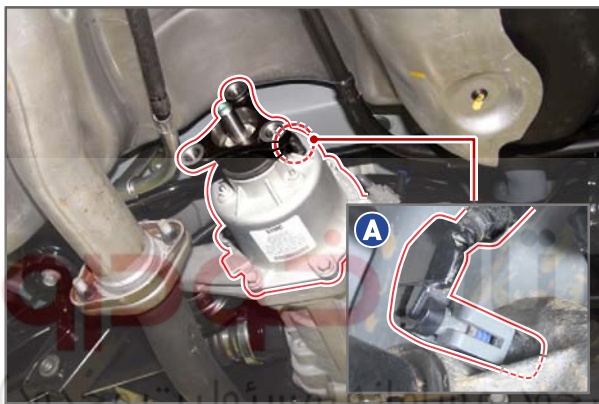

2. Disconnect the connector (A) of the E-coupling.

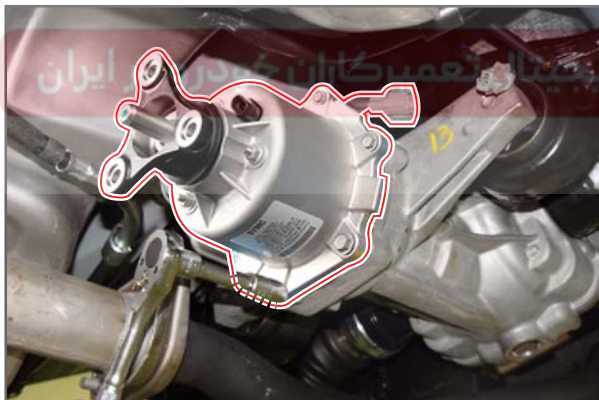

3. Unscrew the 6 mounting bolts (12 mm) on the E-coupling.

Tightening torque 20 ~ 25Nm

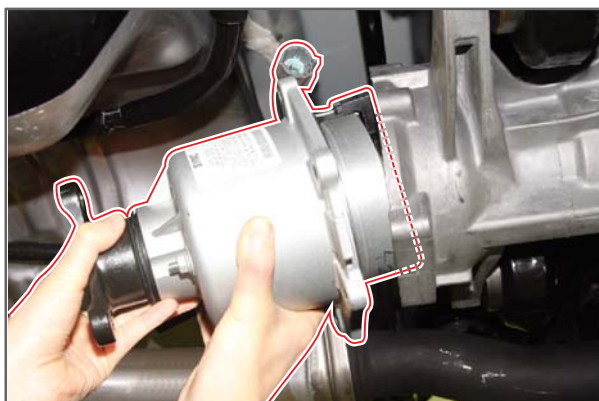

4. Remove the E-coupling from the rear axle.

Modification basis	
Application basis	
Affected VIN	

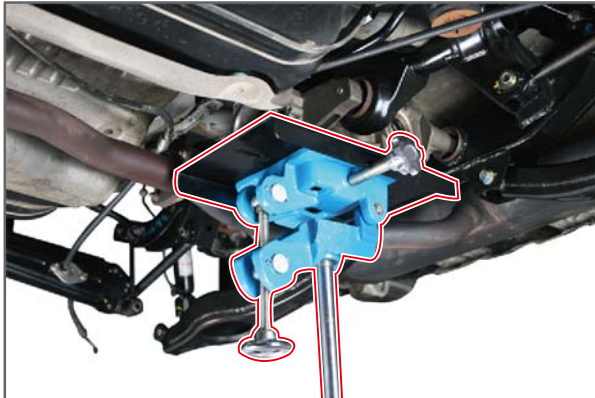

5. Put a jack under the rear axle.

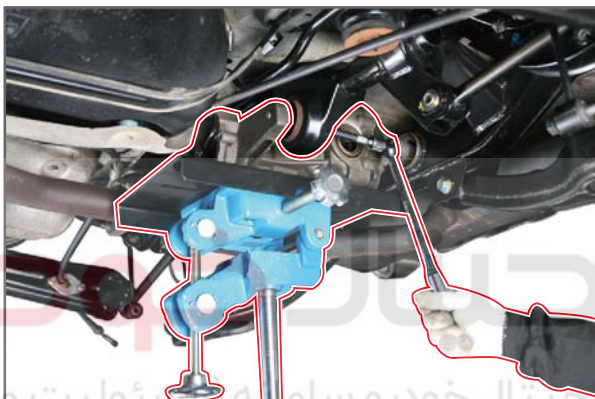

6. Unscrew the two mounting bolts (22 mm) on the left front and the right front sides of the rear axle.

Tightening torque 98.0 to 117.6 Nm

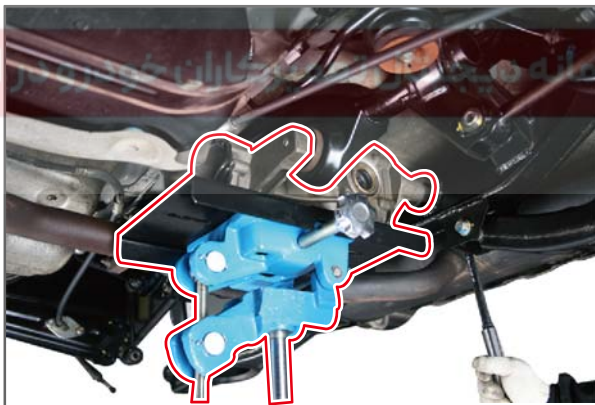

7. Unscrew the two mounting bolts (22 mm) on the left rear and the right rear sides of the rear axle.

Tightening torque 98.0 to 117.6 Nm

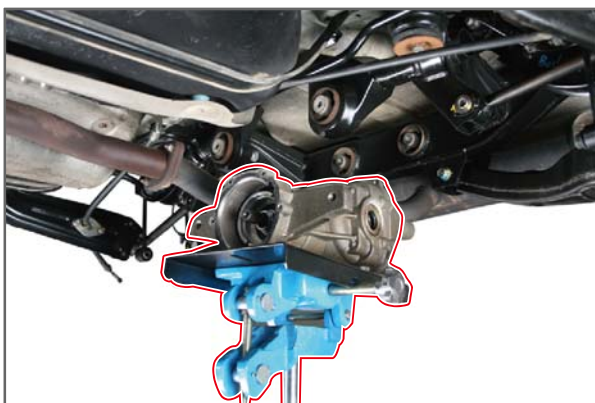

8. Remove the rear axle from the rear sub frame by slowly lowering the axle jack.

Modification basis	
Application basis	
Affected VIN	



9. Install in the reverse order of removal.

CAUTION

Apply EP grease on the spline of the rear axle when installing the rear axle and the E-coupling.

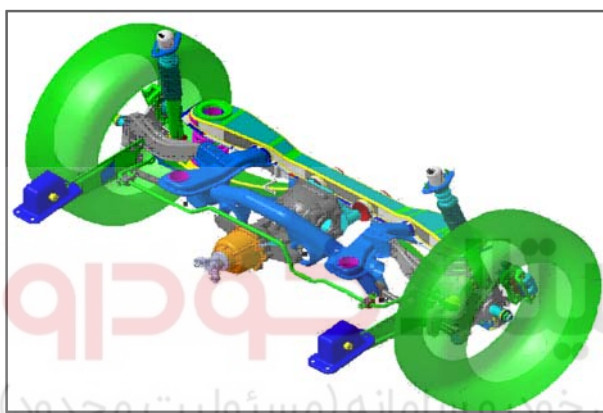

شرکت دیجیتال خودرو سامانه (مسئولیت محدود)

اولین سامانه دیجیتال تعمیرکاران خودرو در ایران

Modification basis	
Application basis	
Affected VIN	

S.G.N.

4220-01

DISASSEMBLY AND REASSEMBLY OF REAR AXLE ASSEMBLY

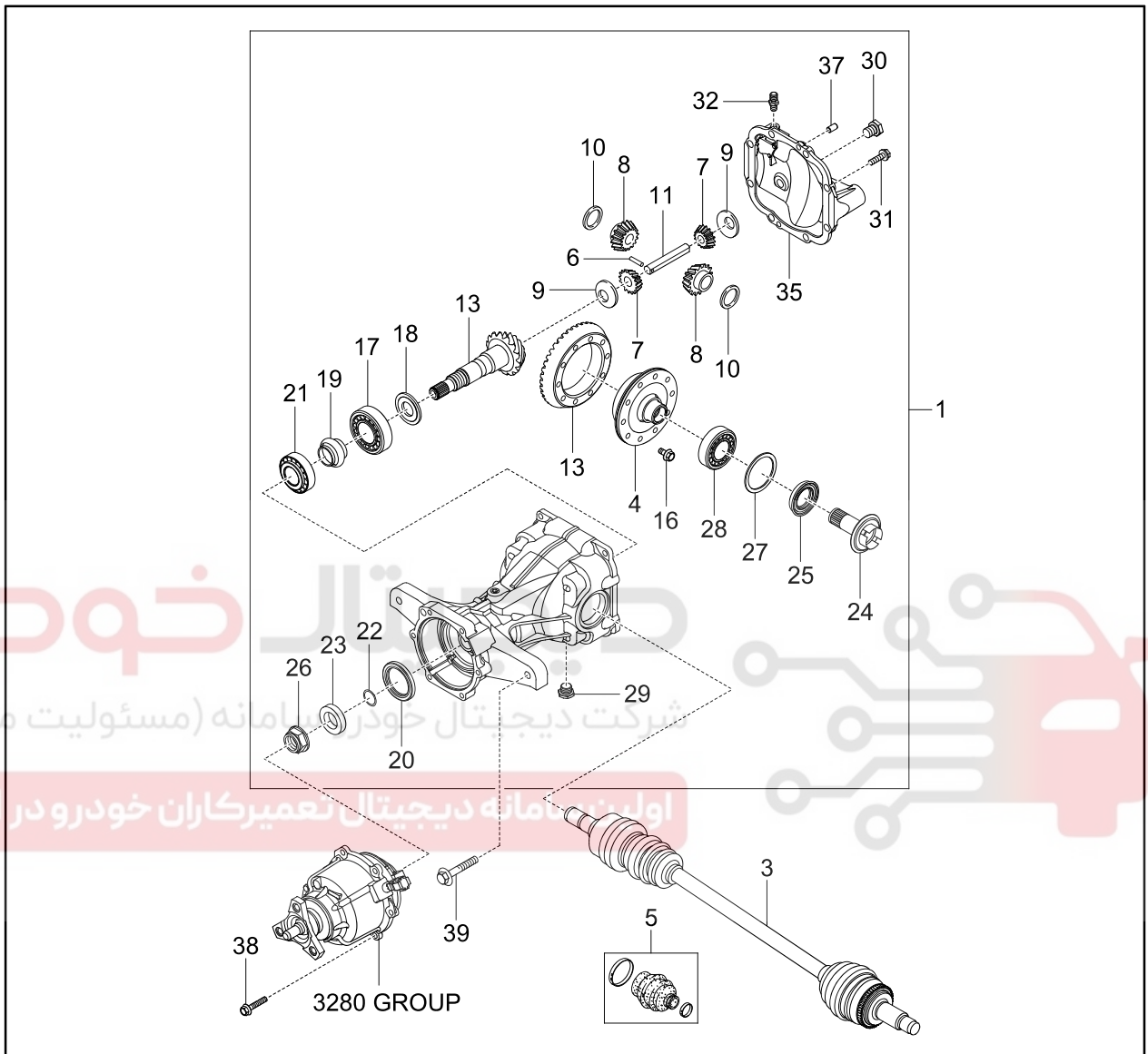

- | | | |
|-------------------------------|--------------------|-------------------------------|
| 1. Rear axle assembly | 13. Drive gear set | 26. Lock nut |
| 3. Rear axle shaft assembly | 16. Bolt | 27. Spacer |
| 4. Differential case assembly | 17. Inner bearing | 28. Differential side bearing |
| 5. Rear axle shaft repair kit | 18. Shim | 29. Drain plug |
| 6. Lock pin | 19. Spacer | 30. Filler plug |
| 7. Differential pinion | 20. Oil seal | 31. Bolt |
| 8. Differential gear | 21. Outer bearing | 32. Vent plug |
| 9. Washer | 22. O-ring | 35. Cover assembly |
| 10. Washer | 23. Oil seal guide | 37. Dowel pin |
| 11. Differential pinion shaft | 24. Protector | 38. Flange bolt |
| | 25. Oil seal | 39. Bolt |

Modification basis	
Application basis	
Affected VIN	

DRIVE SHAFT AND AXLE

KORANDO 2015.01

CHASSIS GENERAL
DSI 6 SPEED
AISIN 6 SPEED
HPT 6AT(6F2)
6-SPEED MT
CLUTCH
PROPELLER
DRIVE SHAFT
SUSPENSION
AWD
BRAKE SYSTEM
ANTI-LOCK
ELECTRONIC
POWER STEERING
ELECTRIC POWER
WHEEL & TIRE
SUB FRAME

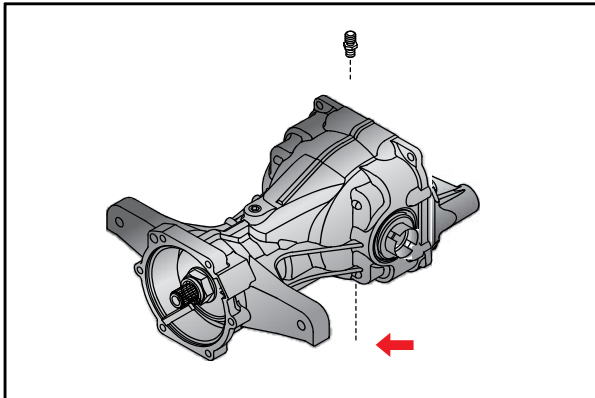

► **Rear differential carrier**

1. Remove the drain plug and drain the oil into an appropriate container before disassembling the rear differential carrier.

Tightening torque 49.0 ~ 68.6Nm

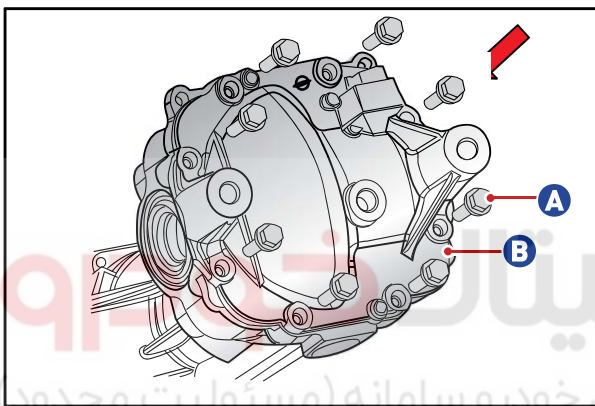

2. Unscrew bolts (A) and remove the cover (B).

Tightening torque 39.2 ~ 49.0Nm

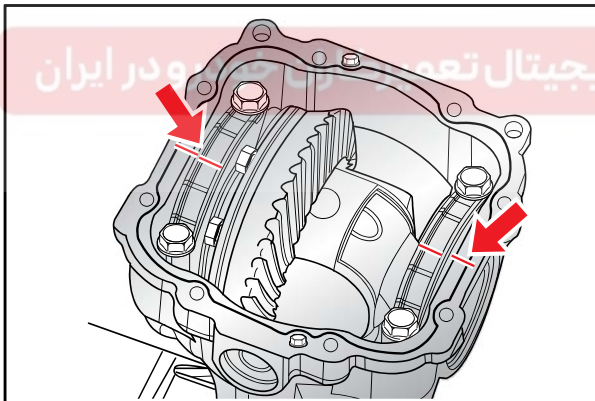

3. Put match marks on the bearing not to mix up the left and right sides before disassembling the differential assembly.

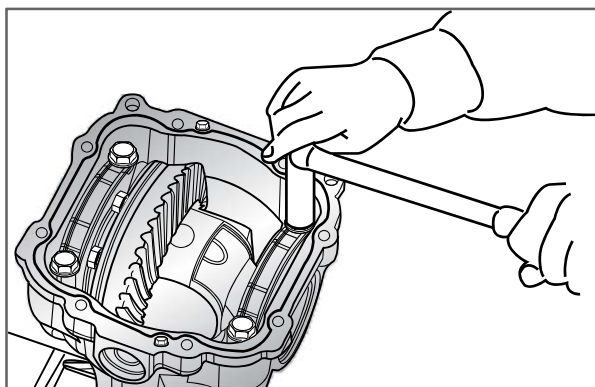

4. Unscrew the bolts and remove the bearing cap.

Tightening torque 44.1 ~ 53.9Nm

Modification basis	
Application basis	
Affected VIN	

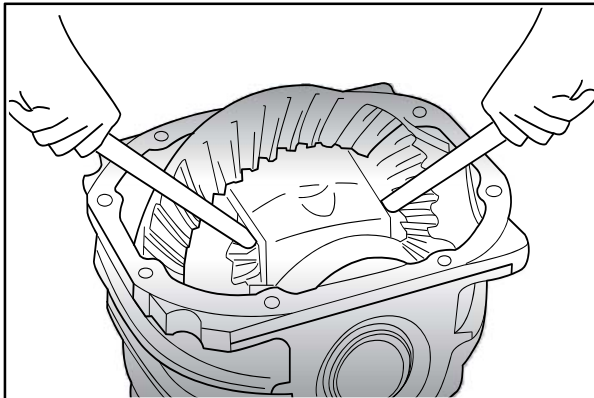

5. Remove the differential assembly using a tool.

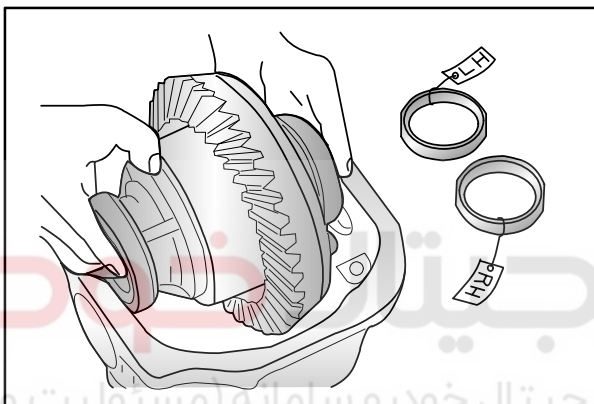

6. Attach labels to the side bearing races (left and right) not to be mixed up.

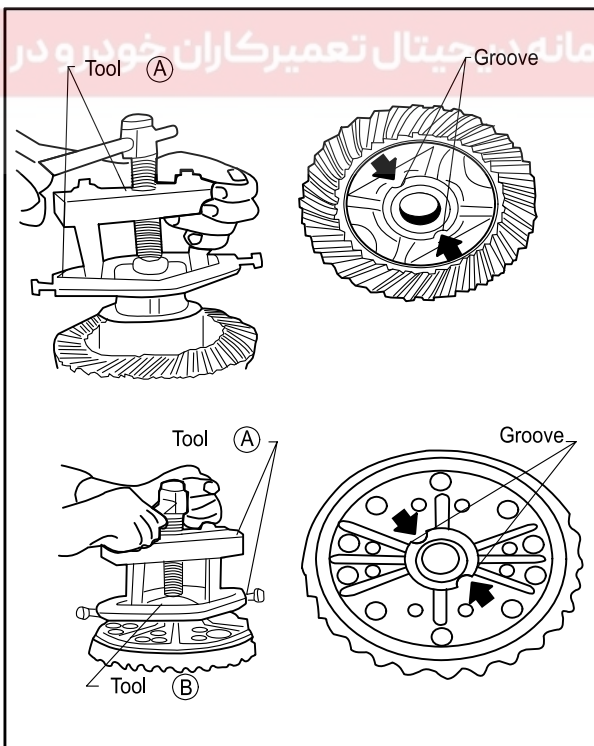

► **Differential assembly**

7. Fit the tool to the grooves on the differential case and then remove the bearing while paying attention not to damage it.

Modification basis	
Application basis	
Affected VIN	

- CHASSIS GENERAL
- DSI 6 SPEED
- AIN 6 SPEED
- HPT 6AT(6F2)
- 6-SPEED M/T
- CLUTCH
- PROPELLER
- DRIVE SHAFT
- SUSPENSION
- AWD
- BRAKE SYSTEM
- ANTI-LOCK
- ELECTRONIC
- POWER STEERING
- ELECTRIC POWER
- WHEEL & TIRE
- SUB FRAME

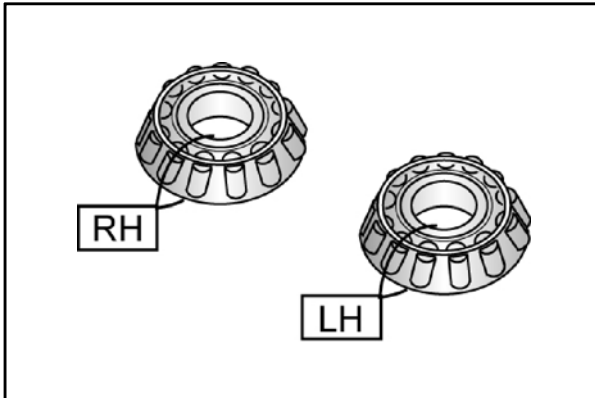

8. Attach labels to the left and right bearings not to mix up after removing them.

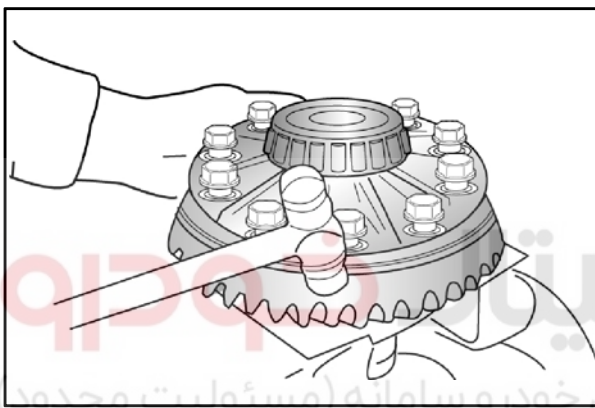

9. Unscrew the ring gear bolts and carefully tap using a rubber hammer to release the drive gear.

Tightening torque 78.4 ~ 88.2Nm

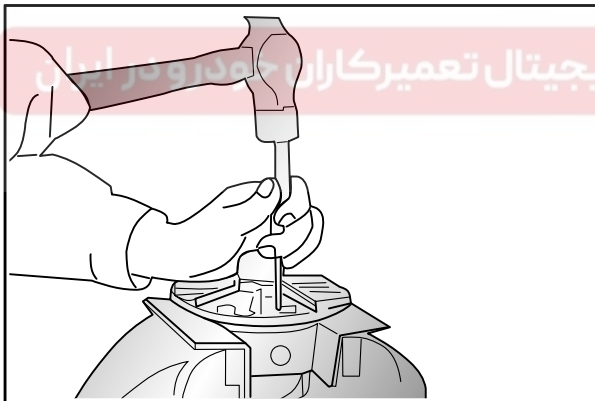

10. Remove the lock pin with a punch.

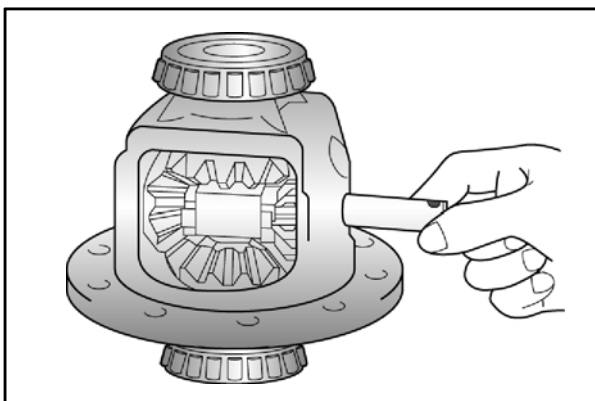

11. Remove the differential shaft.

Modification basis	
Application basis	
Affected VIN	

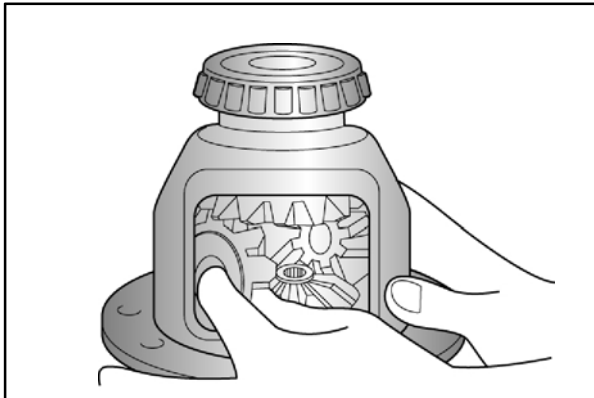

12. Use your finger to remove the differential side gear, the differential pinion gear and the washers as shown in the figure.

NOTE

Measure the backlash after reassembly.
(Specified value: 0~0.08 mm)
If it is out of the specified value, adjust it with the thrust washer in side gear.

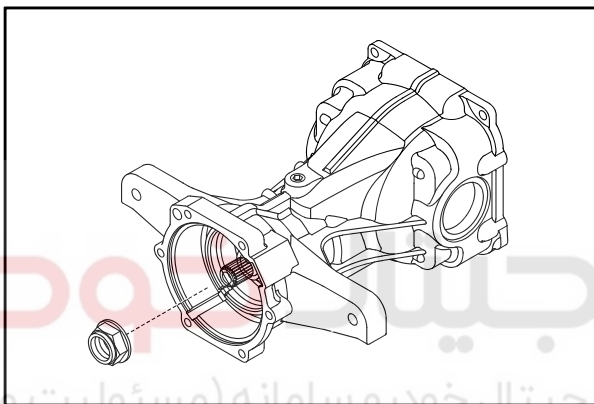

Pinion assembly

13. Unscrew the pinion lock nut.
When installing, tighten the pinion lock nut so that its bearing preload is in the specified value.

Bearing preload	0.9 ~ 1.8Nm
------------------------	-------------

CAUTION

Measure the value while rotating the preload gauge at 60 rpm.

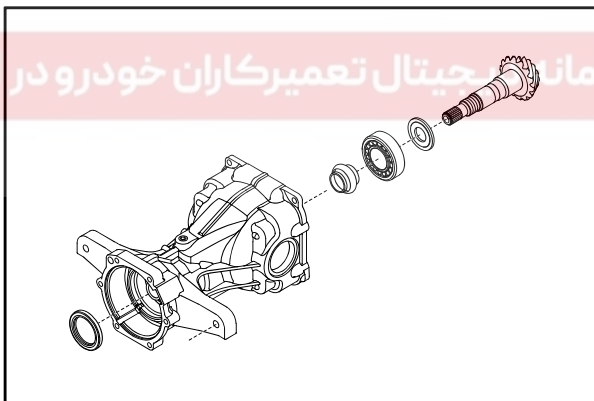

14. Remove the oil seal guide, the pinion gear, the pinion outer bearing and the pinion bearing spacer by pressing the pinion gear with a suitable tool and a press.

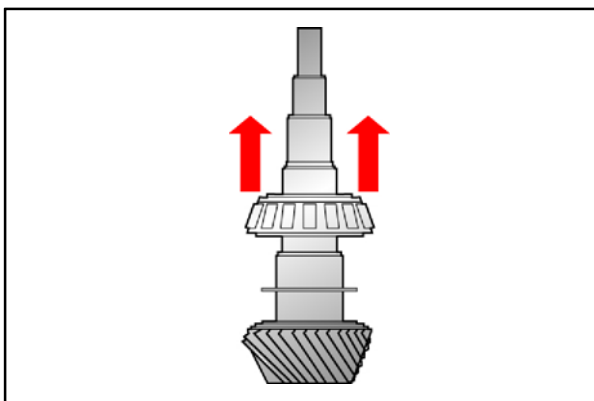

15. Press the pinion gear with a special tool and a press to remove the pinion inner bearing.

Modification basis	
Application basis	
Affected VIN	

- CHASSIS GENERAL
- DSI 6 SPEED
- AIN 6 SPEED
- HPT 6AT(6F2)
- 6-SPEED MT
- CLUTCH
- PROPELLER
- DRIVE SHAFT
- SUSPENSION
- AWD
- BRAKE SYSTEM
- ANTI-LOCK
- ELECTRONIC
- POWER STEERING
- ELECTRIC POWER
- WHEEL & TIRE
- SUB FRAME

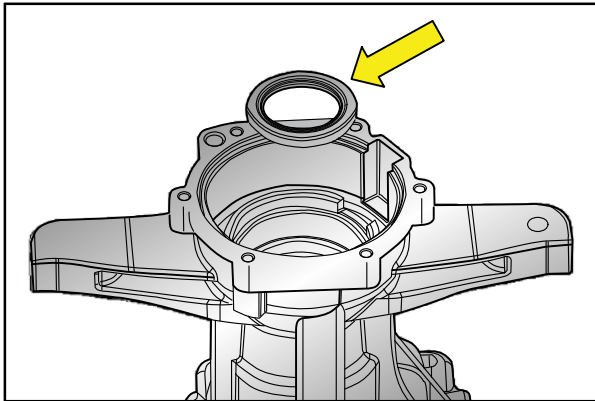

16. Pry out the pinion oil seal with a flat blade screwdriver.

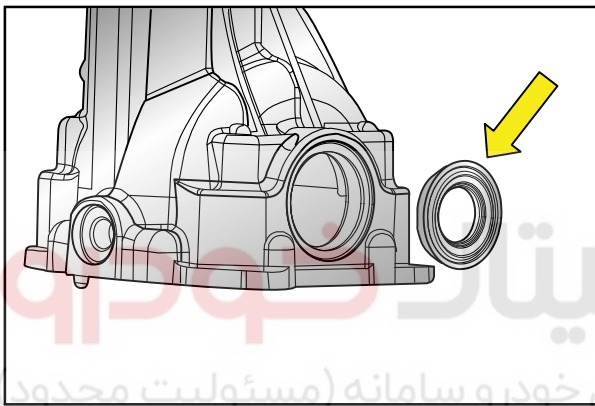

17. Pry out the left and right differential oil seals with a flat blade screwdriver.

18. Reassemble the rear axle assembly in the reverse order of removal.

a. Verify the backlash is within the specification. Adjust with the differential shims if required.

Specified value	0.10 to 0.15 mm
------------------------	-----------------

CAUTION

When the backlash is smaller than the specified value, adjust the thickness of the differential shims. Reduce the thickness of the left differential shims and add the right differential shims with the same thickness as the left ones removed. If the backlash is not within the specification, perform the above procedure in the opposite way.

b. Remove the filler plug (Tightening torque: 39.2~58.8 Nm) and add the axle oil.

Oil capacity	Approx. 0.7 L
Specification	80W/90 (SYMC genuine oil)

Modification basis	
Application basis	
Affected VIN	

► Inspection

1. Clean the removed parts thoroughly and visually check them for any damage or wear. Perform the following procedures if the removed component is worn or damaged.

Component	Action
Gear set	If the gear tooth or tooth surface is damaged (crack, pitting, nick), replace the gear set with new one.
Bearing	If the bearing roller or race is damaged (crack, pitting, nick, unusual noise when rotating), replace it with new bearing.
Oil seal	Always replace the removed oil seal with new one.
Carrier case	Carrier case If the bearing-seating surface of the carrier is damaged (wear, nick), replace the carrier with new one.
Differential assembly	<ul style="list-style-type: none"> - If the gear tooth or tooth surface is damaged (crack, pitting, nick), replace the gear set with new one. - If the washer surface is damaged (crack, pitting, nick), replace the washer with new one.

شرکت دیجیتال خودرو (مسئولیت محدود)





اولین سامانه دیجیتال تعمیرکاران خودرو در ایران

Modification basis	
Application basis	
Affected VIN	

DRIVE SHAFT AND AXLE

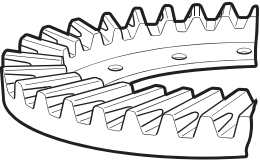
KORANDO 2015.01

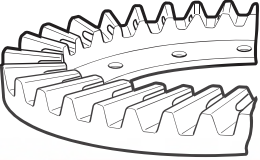
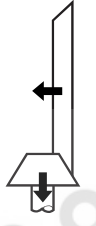
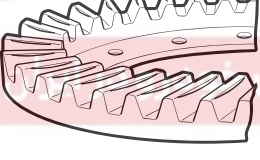
2. Also check the gear set tooth contact pattern.

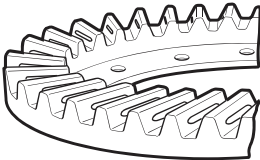
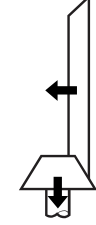
Teeth contact	Cause	Action
<p>1. Wheel contact</p>  <p>A</p>	<p>The backlash is relatively large and noise is generated easily.</p>	<p>Select the shim so that the driving pinion gets close to the ring gear. Then, adjust the backlash.</p>  <p>B</p>
<p>2. Toe contact</p>  <p>A</p>	<p>The backlash is relatively small. Teeth are easily damaged if loaded heavily.</p>	<p>Select the shim so that the driving pinion gets away from the ring gear. Then, adjust the backlash.</p>  <p>B</p>
<p>3. Face contact</p>  <p>A</p>	<p>The backlash is large and noise occurs since the driving pinion shaft is too distant from the ring gear.</p>	<p>Increase the thickness of the driving pinion shim so that the driving pinion is moved toward the ring gear. Then, adjust the backlash.</p>  <p>B</p>
<p>4. Plank contact</p>  <p>A</p>	<p>The gear is in contact with the inner section of the teeth. Since the backlash is too small, gear damage, noise and wear can occur.</p>	<p>Decrease the thickness of the driving pinion shim so that the ring gear gets close to the driving pinion. Then, adjust the backlash.</p>  <p>B</p>

Modification basis	
Application basis	
Affected VIN	